



Instruction Manual

Model

750A

Reference
Voltage Divider

TABLE OF CONTENTS

Section	Title	Page
I	INTRODUCTION AND SPECIFICATIONS	1-1
	1-1. Introduction	1-1
	1-5. Specifications	1-1
II	OPERATING INSTRUCTIONS	2-1
	2-1. Introduction	2-1
	2-3. Temperature Control	2-1
	2-5. Functions of Controls and Terminals	2-1
	2-7. Use in a DC Calibration System	2-1
	2-9. Operation of the DC Calibration System	2-1
	2-11. Applications	2-3
	2-12. Calibrating Voltage Standards	2-3
	2-14. DC Voltage Stability Measurements	2-3
	2-16. Notes on Operation	2-6
	2-17. Standard Cells	2-6
	2-20. Overvoltage Trip	2-6
	2-22. Output Current	2-6
	2-24. Servicing Information	2-6
III	THEORY OF OPERATION	3-1
	3-1. Purpose of the Model 750A	3-1
	3-3. The Main Divider String	3-1
	3-5. Standard Cell Voltage Controls	3-1
	3-7. Overvoltage Circuit	3-1

Section	Title	Page
IV	MAINTENANCE	4-1
4-1.	Introduction	4-1
4-3.	Test Equipment Required for Maintenance	4-1
4-5.	Preventive Maintenance	4-1
4-7.	Battery Replacement	4-1
4-9.	Leakage Resistance Test	4-2
4-11.	Cleaning	4-2
4-13.	Calibration	4-2
4-14.	General Discussion	4-2
4-16.	Overvoltage Trip Check	4-2
4-17.	Calibration Check of 0.1, 0.5, and 1 Volt Taps	4-3
4-18.	Calibration of the Standard Cell Output and 1.1 Volt Taps	4-3
4-19.	Calibration of the 5, 10, 50, 100, 500, 1000, 1100 Volt Taps	4-3
4-20.	Troubleshooting	4-6
4-22.	Checking the Main Divider String	4-6
4-25.	Checking the Standard Cell Voltage Circuit	4-6
4-27.	Troubles in the Overvoltage Circuit	4-7
4-29.	Repair	4-7
V	LIST OF REPLACEABLE PARTS	5-1
5-1.	Introduction	5-1
5-3.	Columnar Information	5-1
5-4.	How to Obtain Parts	5-2
5-7.	Abbreviations and Symbols	5-2
5-8.	Serial Number Effectivity	5-16
APPENDIX A		
JOHN FLUKE MFG. CO. WARRANTY		
LIST OF SALES REPRESENTATIVES		
SCHEMATIC DIAGRAM		

LIST OF ILLUSTRATIONS

Figure	Title	Page
Frontispiece	Model 750A Reference Voltage Divider	iii
1-1.	Model 750A Outline Drawing	1-2
2-1.	Location and Function of Controls and Terminals	2-2
2-2.	Recommended Components of a DC Calibration System	2-3
2-3.	Equipment Connections for a DC Calibration System	2-4
2-4.	Equipment Connections for Stability Measurements	2-5
4-1.	Test Equipment Required for Maintenance	4-1
4-2.	Battery Location	4-2
4-3.	Equipment Connections for Leakage Resistance Test	4-4
4-4.	Equipment Connections for Calibration	4-5
4-5.	Tap Calibration Steps	4-8
5-1.	Final Assembly	5-3
5-2.	Front Panel Assembly	5-4
5-3.	Kelvin-Varley Switch Assemblies (Sheet 1 of 2)	5-7
5-3.	Kelvin-Varley Switch Assemblies (Sheet 2 of 2)	5-8
5-4.	Chassis Assembly	5-10
5-5.	Adjustment P/C Assemblies No. 1 thru No. 8	5-13
5-6.	Protection P/C Assembly	5-14
5-7.	Pot Mounting P/C Assembly	5-15



MODEL 750A REFERENCE VOLTAGE DIVIDER

SECTION I

INTRODUCTION AND SPECIFICATIONS

1-1. INTRODUCTION

1-2. The Fluke Model 750A is an extremely accurate and stable reference voltage divider having an input voltage range of 1100 to 1.1 volts dc and an output voltage range of 1100 to 0.1 volts dc. It is intended primarily for the purpose of making traceable measurements through use with a null detector and a standard cell. The combination of reference divider and null detector compares the output voltage of the divider to the standard cell voltage. Traceability is from the divider ratios to the standard cell in use, to the primary standard cell, to the inter-laboratory standard cell, and then to the National Bureau of Standards.

1-3. The primary application of the Model 750A is that of a stable accurate ratio reference for use in a dc calibration system including a voltage source, a standard cell and a null detector. Such a calibration system may be used as a reference for voltage stability measurements by utilizing the recorder output of the null detector as the common input of a recorder. In this application, the stability of the reference approaches that of the standard cell. The Model 750A may also be used as a volt box to extend the measurement range of laboratory potentiometers.

1-4. The use of switches for the selection of input and output voltage taps makes the Model 750A fast and convenient to use. Adjustment potentiometers in the divider string eliminate the need for correction curves. An overvoltage protection circuit is included to prevent operator error from causing damage to the instrument.

1-5. SPECIFICATIONS

INPUT VOLTAGES (Switched)

1.1, 5, 10, 50, 100, 500, 1000, 1100 volts dc.

OUTPUT VOLTAGES (Switched)

0.1, 0.5, 1, 1.1, 5, 10, 50, 100, 500, 1000, 1100 volts dc.

STANDARDIZING OUTPUT

1.017000 to 1.019999 volts dc in 1 microvolt steps.

DIVISION RATIO ACCURACY AND STABILITY (Referenced to Standard Cell Tap) $\pm(0.001\%$ of output + 0.5 microvolt) for 1 year.

CALIBRATION

All taps 1.1 volt and above are adjustable to ± 10 ppm.

CALIBRATION RESOLUTION

0.2 ppm.

DIVIDER CURRENT

1 milliampere nominal.

INPUT CURRENT ADJUST

Coarse and fine front-panel rheostats provide an input voltage adjustment span of 10 millivolt with better than 1 microvolt resolution.

OVERVOLTAGE PROTECTION

Up to 2,000 volts may be applied on any input range without damage.

OPERATING TEMPERATURE RANGE

15° C to 35° C.

TEMPERATURE COEFFICIENT OF OUTPUT

± 1 ppm/° C over operating range.

INITIAL CALIBRATION TEMPERATURE

23(± 1)° C.

STORAGE TEMPERATURE RANGE

-62° C to +70° C.

HUMIDITY

0 to 80%.

SHOCK

Meets 20g, 11 ms shock tests of MIL-E-4970A.

VIBRATION

Meets 10 Hz - 55 Hz tests of MIL-T-945A.

POWER

Two 6.75 volt mercury batteries power the over-voltage protection circuit. Recommended replacement interval is 1 year.

SIZE

3-1/2" high x 19" wide x 13" behind panel.

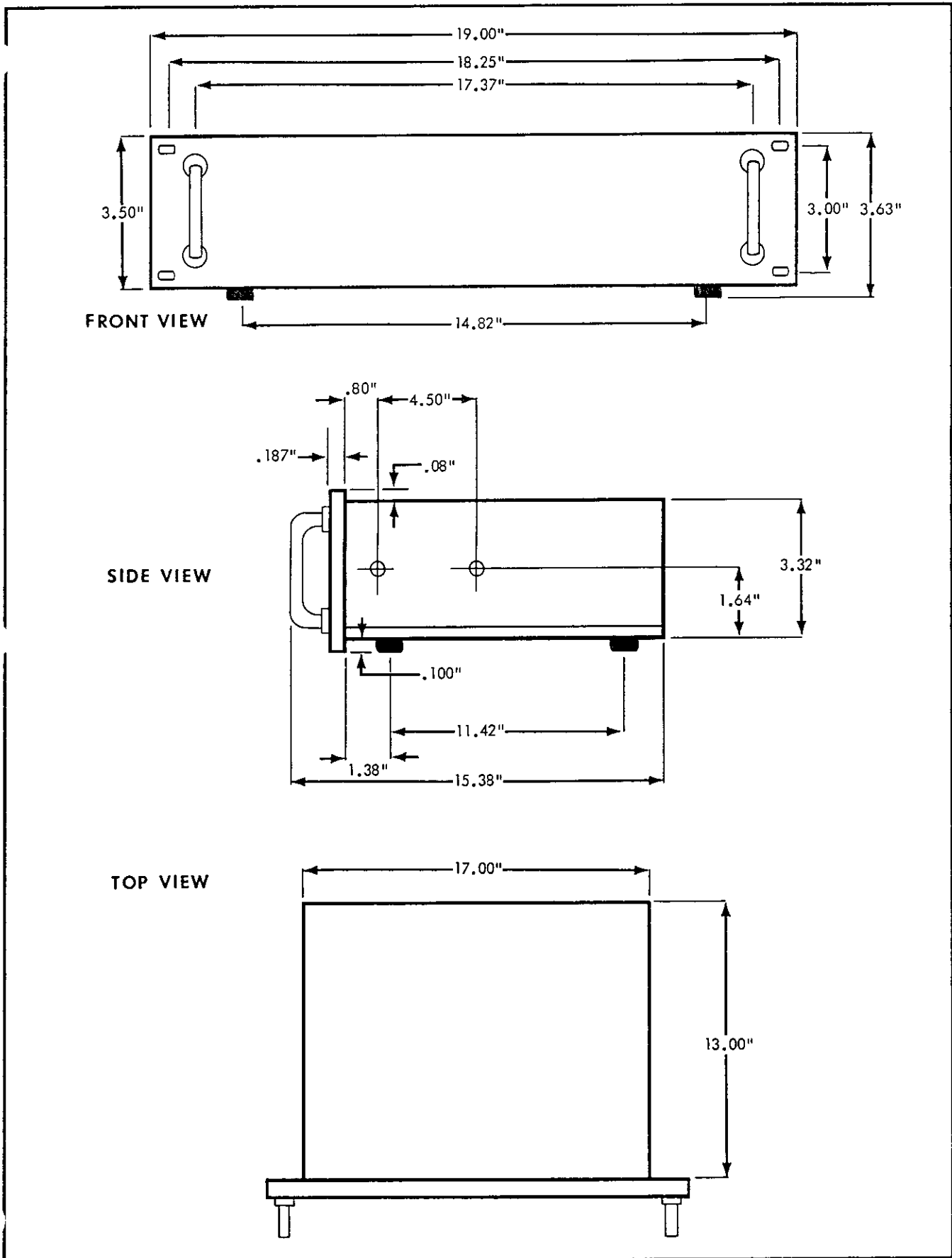

Figure 1-1. OUTLINE DRAWING



static awareness



A Message From
John Fluke Mfg. Co., Inc.

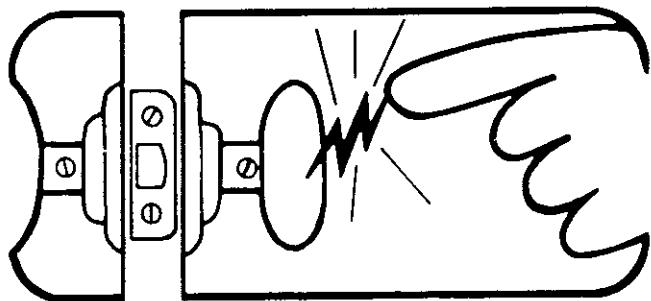

Some semiconductors and custom IC's can be damaged by electrostatic discharge during handling. This notice explains how you can minimize the chances of destroying such devices by:

1. Knowing that there is a problem.
2. Learning the guidelines for handling them.
3. Using the procedures, and packaging and bench techniques that are recommended.

The Static Sensitive (S.S.) devices are identified in the Fluke technical manual parts list with the symbol



The following practices should be followed to minimize damage to S.S. devices.

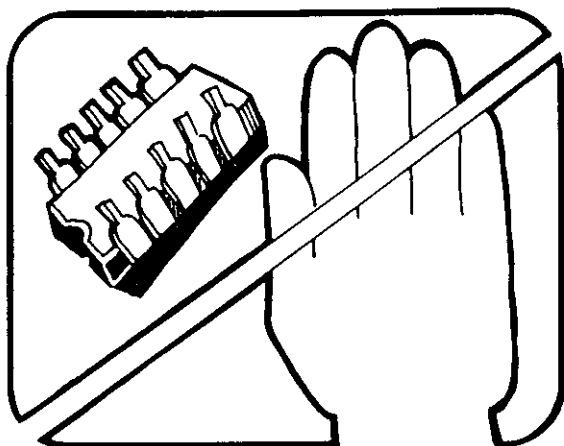

1. MINIMIZE HANDLING

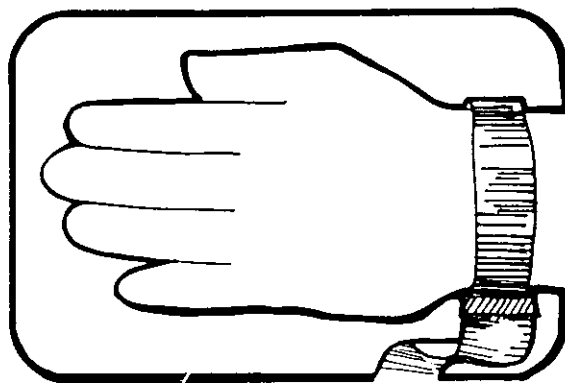

3. DISCHARGE PERSONAL STATIC BEFORE HANDLING DEVICES

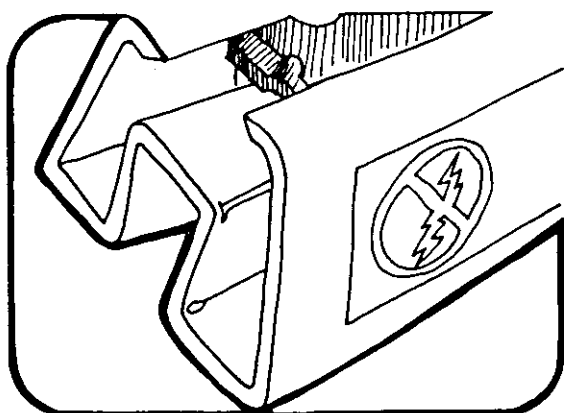

2. KEEP PARTS IN ORIGINAL CONTAINERS UNTIL READY FOR USE.

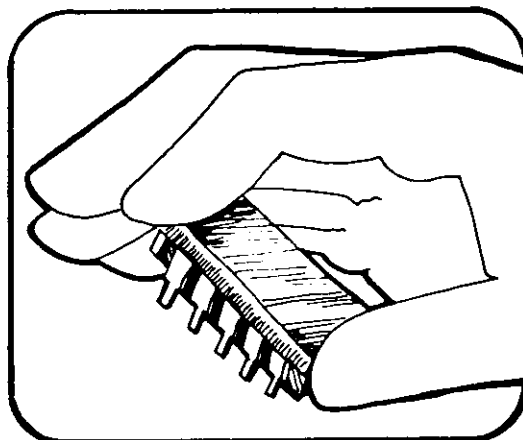

4. HANDLE S.S. DEVICES BY THE BODY

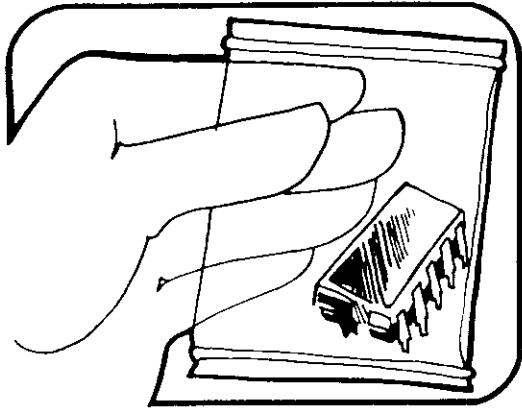

5. USE ANTI-STATIC CONTAINERS FOR HANDLING AND TRANSPORT

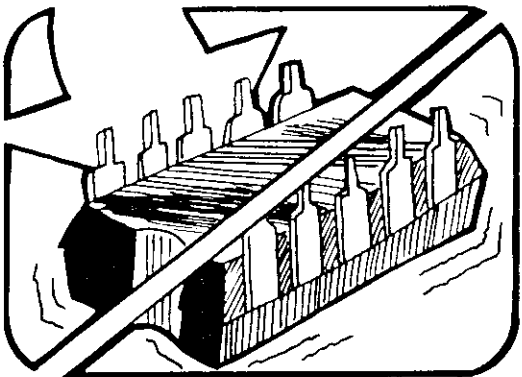

6. DO NOT SLIDE S.S. DEVICES OVER ANY SURFACE

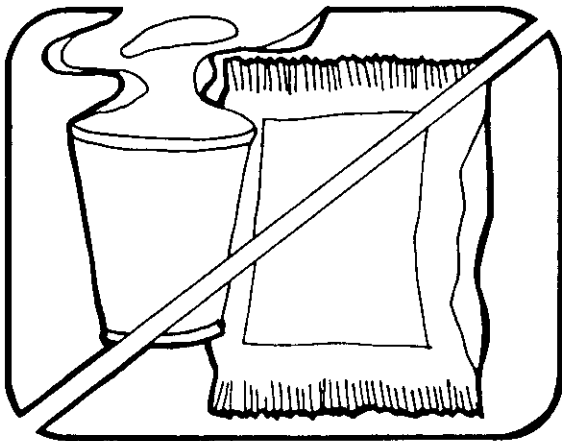

7. AVOID PLASTIC, VINYL AND STYROFOAM® IN WORK AREA

PORTIONS REPRINTED
WITH PERMISSION FROM TEKTRONIX, INC.
AND GENERAL DYNAMICS, POMONA DIV.

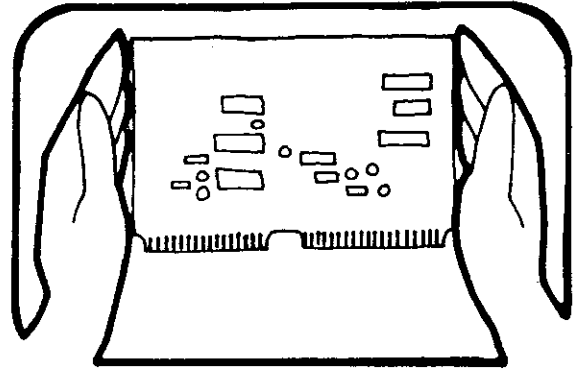

8. WHEN REMOVING PLUG-IN ASSEMBLIES, HANDLE ONLY BY NON-CONDUCTIVE EDGES AND NEVER TOUCH OPEN EDGE CONNECTOR EXCEPT AT STATIC-FREE WORK STATION. PLACING SHORTING STRIPS ON EDGE CONNECTOR USUALLY PROVIDES COMPLETE PROTECTION TO INSTALLED SS DEVICES.

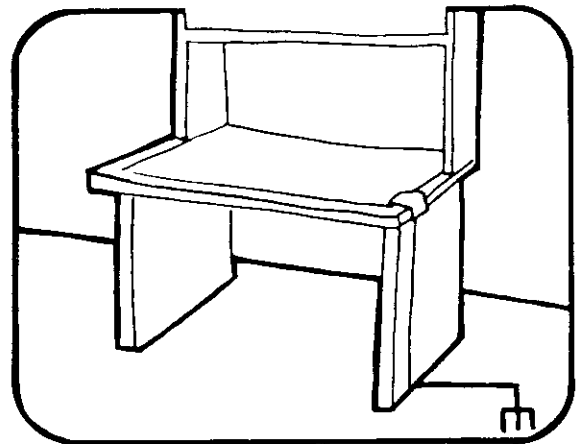

9. HANDLE S.S. DEVICES ONLY AT A STATIC-FREE WORK STATION
10. ONLY ANTI-STATIC TYPE SOLDER-SUCKERS SHOULD BE USED.
11. ONLY GROUNDED TIP SOLDERING IRONS SHOULD BE USED.

Anti-static bags, for storing S.S. devices or pcbs with these devices on them, can be ordered from the John Fluke Mfg. Co., Inc.. See section 5 in any Fluke technical manual for ordering instructions. Use the following part numbers when ordering these special bags.

John Fluke Part No.	Description
453522	6" X 8" Bag
453530	8" X 12" Bag
453548	16" X 24" Bag
454025	12" X 15" Bag
Pink Poly Sheet	Wrist Strap
30"x60"x60 Mil	P/N TL6-60
P/N RC-AS-1200	\$7.00
\$20.00	

SECTION II

OPERATING INSTRUCTIONS

2-1. INTRODUCTION

2-2. This section contains the instructions for use and operation of the Fluke Model 750A. Instructions for use and operation in a dc calibration system and in a dc voltage stability test setup have been included because the primary purpose of the instrument is to provide a means of making voltage measurements of known absolute accuracy traceable to the National Bureau of Standards through a standard cell.

2-3. TEMPERATURE CONTROL

43.4° F → 2-4. The Fluke Model 750A is factory calibrated at $23 \pm 1^\circ \text{C}$, and has a temperature coefficient of $\pm 1 \text{ ppm}/^\circ \text{C}$. If the instrument is to be used in an environment significantly different from 23°C , it must be recalibrated at the operating temperature or the appropriate derating must be applied to the accuracy of measurement.

2-5. FUNCTIONS OF CONTROLS AND TERMINALS

2-6. The name and function of the controls, terminals, and indicators of the Model 750A may be found in Figure 2-1. The numbered arrow callouts, of Figure 2-1, correspond to the reference numbers in the chart of the same figure.

2-7. USE IN A DC CALIBRATION SYSTEM

2-8. The Model 750A, a dc voltage source, a null detector, and a standard cell comprise a dc calibration system with accuracy of 10 to 30 ppm, depending on the accuracy of the auxiliary equipment used. A list of recommended equipment is given in Figure 2-2.

2-9. OPERATION OF THE DC CALIBRATION SYSTEM

2-10. A dc calibration system based on the Model 750A Reference Divider is shown in Figure 2-3. Connect the equipment as follows:

- a. Set INPUT VOLTAGE switch to RESET.
- b. Connect the power supply to the INPUT VOLTAGE terminals.

Note!

If a power supply with a grounded output is used, the instrument being calibrated must be ungrounded to avoid ground loop problems.

- c. Set the polarity switch of the power supply and set the output voltage to the desired output.
- d. Set the STANDARD CELL switch to OPEN and set the STANDARD CELL VOLTAGE dials to the correct standard cell voltage.

CAUTION!

The standard cell polarity and the power supply polarity must agree to avoid damaging the standard cell by drawing excessive current from it.

- e. Connect the null detector to the NULL DETECTOR binding posts and connect a standard cell to the STANDARD CELL binding posts. This places the null detector and the standard cell in series.

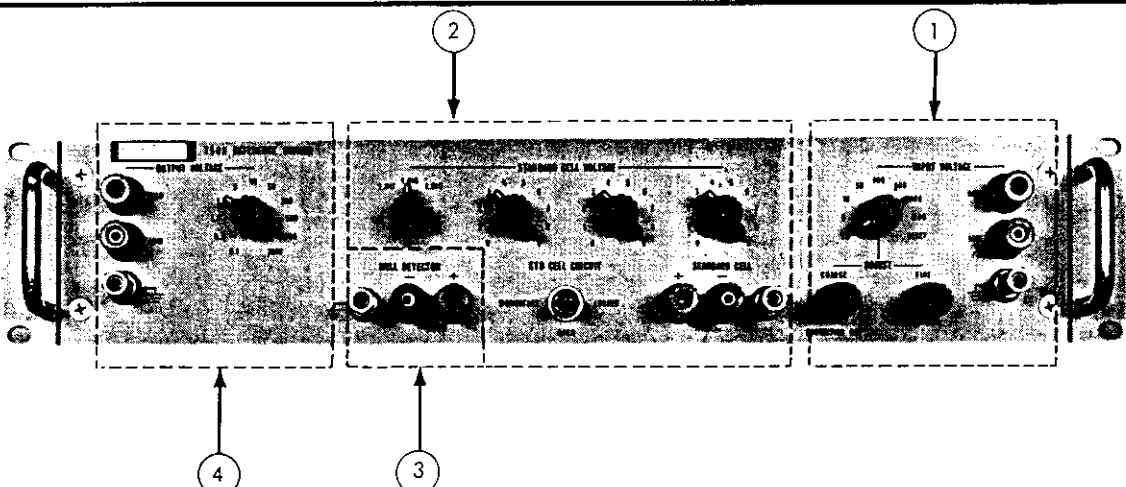

	CONTROL OR TERMINAL	FUNCTION
①	INPUT VOLTAGE rotary switch red terminal black terminal metallic terminal COARSE ADJUST FINE ADJUST	Used to select the desired input voltage from 1.1 to 1100 volts. In RESET position, disconnects divider string from input terminals and resets overvoltage trip. High input terminal for connection of input voltage. Low input terminal for connection of input voltage. Chassis ground terminal for convenience. Coarse trimmer for input voltage adjustment. Fine trimmer for input voltage adjustment.
②	STANDARD CELL VOLTAGE four rotary switches STANDARD CELL red terminal black terminal metallic terminal STD CELL CIRCUIT	Used to set standardizing output of Model 750A to the voltage of the standard cell in use. Any voltage from 1.017000 to 1.019999 may be selected. Used to connect positive terminal of standard cell to reference divider. Used to connect negative terminal of standard cell to reference divider. Chassis ground terminal for convenience. Toggle switch closes the standard cell circuit to standardize the divider input. Closure may be MOMENTARY or LOCKED.
③	NULL DETECTOR red terminal black terminal metallic terminal	Used to connect input terminal of null detector to reference divider. Used to connect common terminal of null detector to reference divider. Chassis ground terminal for convenience.
④	OUTPUT VOLTAGE rotary switch red terminal black terminal metallic terminal	Used to select the desired output voltage from 0.1 to 1100 volts. The selected output voltage must be no higher than the input voltage. High output terminal. Low output terminal. Chassis ground terminal for convenience.

Figure 2-1. LOCATION AND FUNCTION OF CONTROLS AND TERMINALS

RECOMMENDED EQUIPMENT	SPECIFICATIONS
DC Voltage Source, Fluke Model 332B	Output voltage to 1100 volts. Minimum noise and ripple, and maximum short-term stability.
Null Detector, Fluke Model 845AB	Full scale sensitivity of 10 uv or better. High input resistance and battery operation are preferred.
Standard cells and enclosure, Guildline Instruments, Model 9152/P4	Saturated cells are recommended. However unsaturated cells may be used with reduced accuracy. Leakage resistance must be at least 10^{11} ohms.

Figure 2-2. RECOMMENDED COMPONENTS OF A DC CALIBRATION SYSTEM

- f. Set the INPUT VOLTAGE switch to the desired input voltage.
- g. Set the OUTPUT VOLTAGE switch to the desired output.
- h. Turn on all equipment including the power supply output and allow it to warm up until it reaches temperature equilibrium.
- i. Set the null detector to reduced sensitivity (1 volt, for example).
- j. Throw the STANDARD CELL switch to MOMENTARY and note deflection of the null detector. Adjust the COARSE and FINE INPUT VOLTAGE controls and, if necessary, the power supply output voltage to obtain a zero indication on the null detector. Increase sensitivity of the null detector as null is approached. Final null should be on the 10 microvolt range.
- k. The selected output voltage is now available at the OUTPUT VOLTAGE terminals and it may be used as a calibration source.

2-11. APPLICATIONS

2-12. CALIBRATING VOLTAGE STANDARDS

2-13. Voltage standards or calibrated power supplies can be calibrated with only the Model 750A, a standard cell, and a null detector. Proceed as follows:

- a. Set the STANDARD CELL VOLTAGE dials to the correct standard cell voltage.
- b. Set the STANDARD CELL switch to OPEN, and set the null detector for reduced sensitivity.
- c. Connect the null detector to the NULL detector binding posts and connect a standard cell to the standard cell binding post.
- d. Set the INPUT VOLTAGE switch to RESET.

Note!

Setting the INPUT VOLTAGE switch to RESET disconnects the input terminals and the overvoltage circuit. Failure to set the switch to reset may, at certain output settings, permit sufficient current flow in the overvoltage circuit to seriously impair the accuracy of the calibration being performed.

- e. Connect the instrument to be calibrated to the OUTPUT VOLTAGE binding posts and set the OUTPUT VOLTAGE switch to 1100.

CAUTION!

The overvoltage protective circuit is inoperative when voltage is applied to the output binding posts. Care must be taken to prevent decreasing the setting of the OUTPUT VOLTAGE switch without first decreasing the applied voltage. Failure to observe this precaution may damage the equipment.

- f. Turn on the equipment and allow it to warmup.
- g. Set the output of the instrument being tested to the calibration voltage and set the OUTPUT VOLTAGE switch of the Model 750A to the same voltage.
- h. Throw the standard cell switch to MOMENTARY and note deflection of the null detector.
- i. Adjust the calibration control of the instrument being calibrated increasing null sensitivity until a null is obtained.
- j. Repeat steps g through i for each calibration point.

2-14. DC VOLTAGE STABILITY MEASUREMENTS

2-15. Voltage stability measurements can be referenced to a standard cell by using the test setup shown in Figure 2-4. To make stability measurements, connect the equipment and proceed as follows:

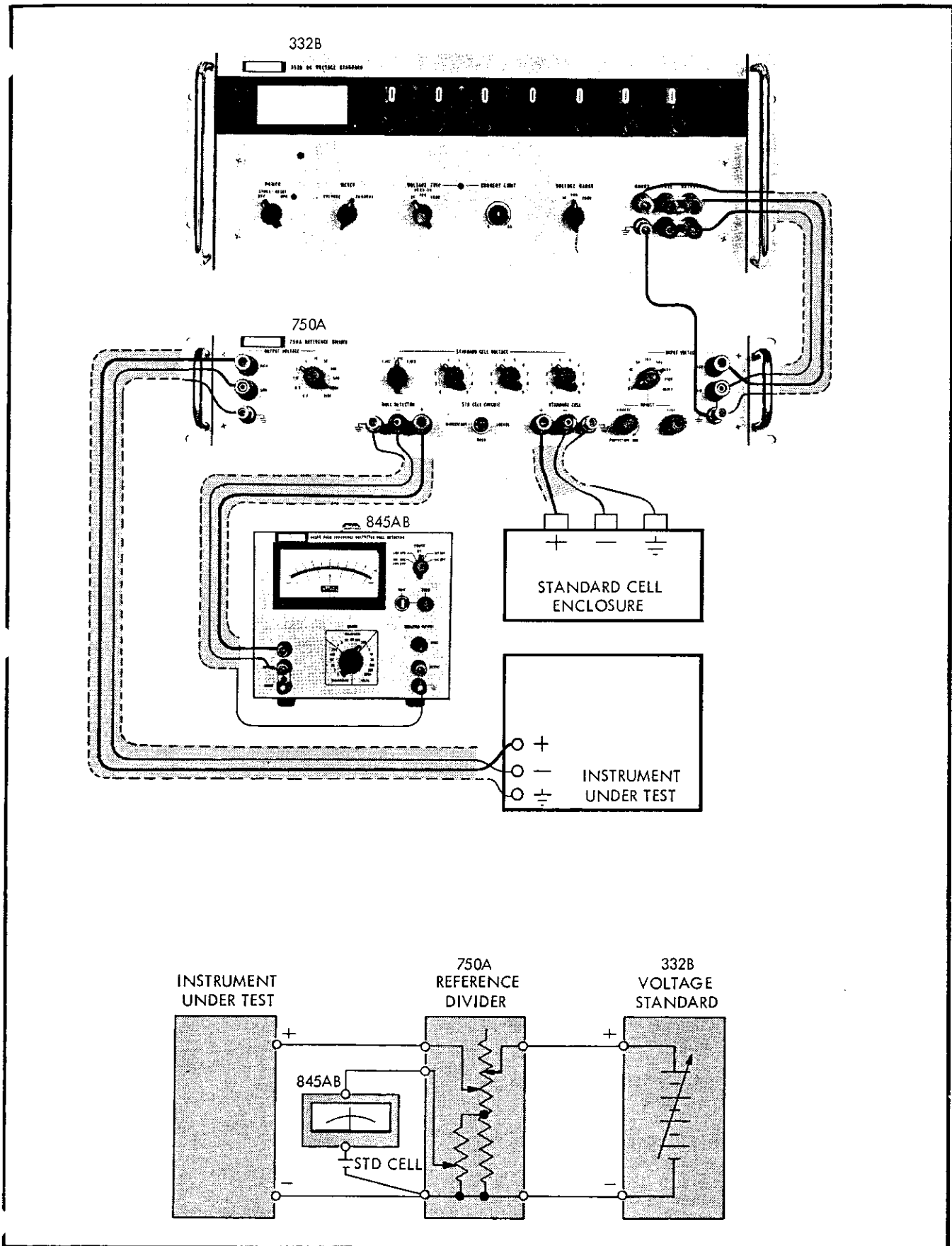

Figure 2-3. EQUIPMENT CONNECTIONS FOR A DC CALIBRATION SYSTEM

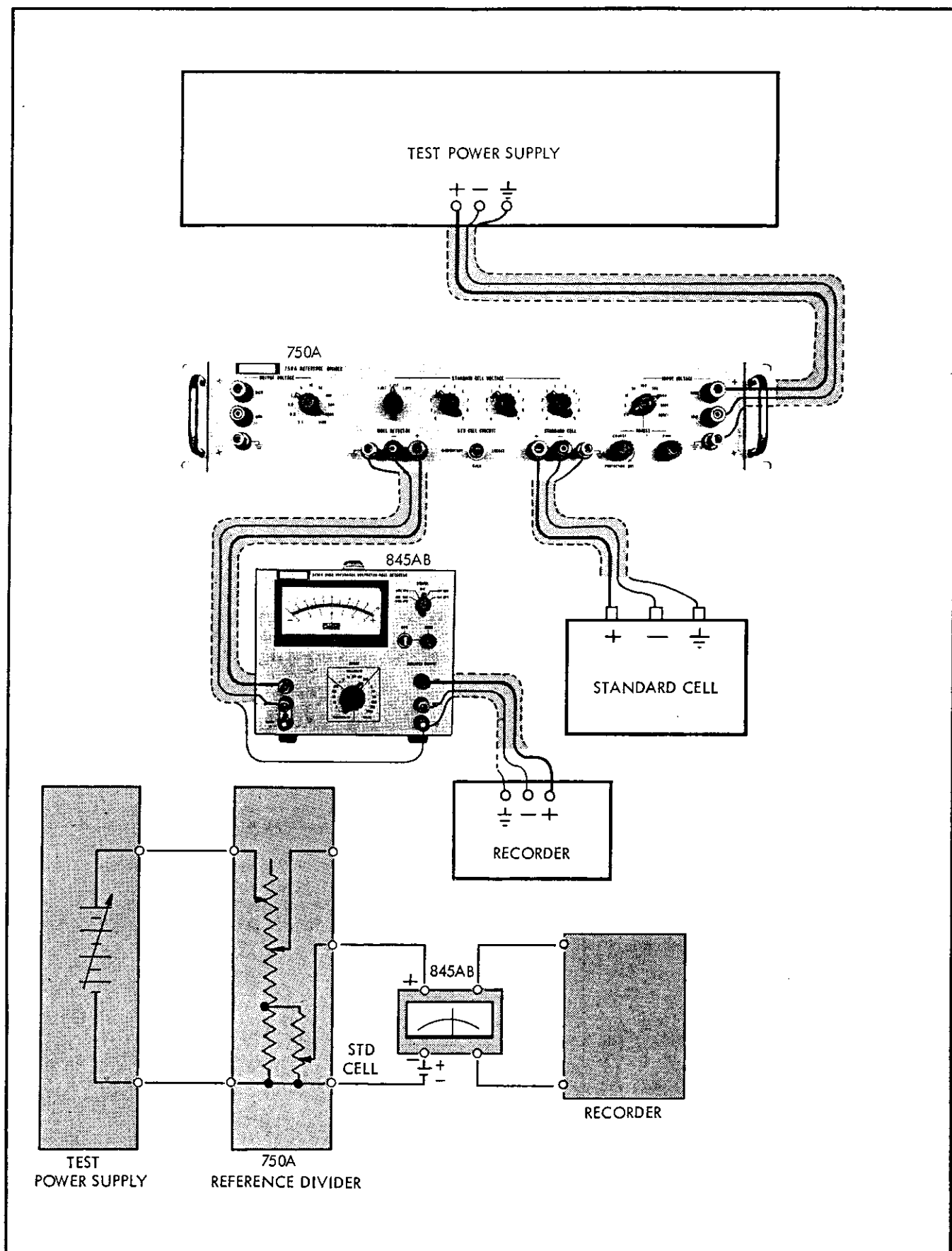

Figure 2-4. EQUIPMENT CONNECTIONS FOR STABILITY MEASUREMENTS

- a. Set the power supply output and the INPUT VOLTAGE switch to the same value.
- b. Turn on the equipment and allow it to warm up until it reaches temperature equilibrium.
- c. Set the STANDARD CELL VOLTAGE dials to the correct standard cell voltage.
- d. Throw the STANDARD CELL switch to MOMENTARY and adjust the COARSE and FINE INPUT VOLTAGE controls to obtain a zero indication on the null detector at the desired sensitivity.
- e. Throw the STANDARD CELL switch to LOCKED position and adjust the recorder output controls of the null detector and the recorder controls to obtain the desired sensitivity on the recording.

Note!

For best results over long intervals it is essential that ambient temperature be maintained at a constant level because of its effect on all parts of the system. If the test is conducted in an environment with a cyclic temperature variation of a few degrees, the stability recording will be found to track the temperature cycles.

2-16. NOTES ON OPERATION

2-17. STANDARD CELLS

2-18. The standard cells provide traceability of the measurement to the National Bureau of Standards. Consequently they should be cared for and used properly. The cells should be compared weekly to saturated cells having traceability to the National Bureau of Standards.

2-19. The function of a standard cell is to provide a fixed standard emf at very low current. Current drain from a standard cell causes a slow, permanent change in cell voltage. If the STANDARD CELL switch is set to LOCKED and the overvoltage trip removes input voltage from the reference divider, the standard cell will discharge through the null detector resistance. Consequently, the STANDARD CELL switch should never be left in the LOCKED position when a null detector

having low input resistance (for example, a galvanometer) is used.

2-20. OVERVOLTAGE TRIP

2-21. The overvoltage trip circuit prevents damage to the divider string resistors caused by reducing the setting of the INPUT VOLTAGE switch without reducing the input voltage. This circuit opens the input when the input voltage exceeds approximately 140% of the INPUT VOLTAGE switch setting. The overvoltage trip circuit is powered by two batteries which should be replaced once a year. See Section IV for battery replacement instructions.

2-22. OUTPUT CURRENT

2-23. Occasionally it may be necessary to provide a small output current at a given output voltage. When this need arises, the input voltage usually should be set to the same level as the output voltage to prevent current flow from the divider string. However, if the power supply being used has poor stability at low voltage, it may be desirable to set the input higher than the output voltage to reduce variation in the output.

Note!

Output current will be limited to approximately 0.4 milliampere by the overvoltage trip circuit.

To draw output current from the divider string, apply the load and increase the input voltage to obtain zero indication on the null detector.

2-24. SERVICING INFORMATION

2-25. The John Fluke Manufacturing Co., Inc. warrants each instrument manufactured by them for the period of one year upon making delivery of the instrument to you, the original purchaser. Complete warranty information is contained in the Warranty page located at the rear of this manual.

2-26. If you should encounter any problem in the operation of your instrument, please feel free to contact your nearest John Fluke Sales Representative or write directly to the John Fluke Manufacturing Co., Inc. with a statement of your problem.

SECTION III

THEORY OF OPERATION

3-1. PURPOSE OF THE MODEL 750A

3-2. The Model 750A provides a means of accurately comparing specific voltages from 0.1 volt to 1100 volts to the known potential of a standard cell. It may be used as a standardizing link in a dc calibration system or it may be used for direct comparison of power supply output and standard cell voltage.

3-3. THE MAIN DIVIDER STRING

3-4. The total effective resistance of the main divider string is 1.1 megohms. The input resistance is 1000 ohms per volt of rated input up to 1100 volts resulting in a nominal current of one milliampere. The input voltage may be adjusted by COARSE and FINE rheostats located on the front panel. The span of adjustment of 10 millivolts and resolution of better than one microvolt permit the operator to achieve an exact null. An adjustment in each step of the main divider string is used to compensate for drift during calibration.

3-5. STANDARD CELL VOLTAGE CONTROLS

3-6. The STANDARD CELL VOLTAGE controls shunt the lower end of the main divider string from common to the 1.1 volt tap. These controls form a modified Kelvin-Varley circuit spanning the range from 1.017000 volts to 1.019999 volts. They are used by the operator to obtain from the divider a voltage which will exactly

equal the standard cell voltage when the input is at nominal value. This voltage is compared to the output of the standard cell by a null detector and the input to the divider is adjusted to obtain a null.

3-7. OVERVOLTAGE CIRCUIT

3-8. The overvoltage circuit (overvoltage trip) removes the input voltage from the divider when it exceeds approximately 1.4 times the setting of the INPUT VOLTAGE switch. The input voltage is applied to base of Q2 through a tapped resistive string which conducts approximately 0.07 milliampere at rated input voltage. Transistor Q2 is biased off when normal operating voltage is applied to the resistive string. Transistor Q1 is held cut off by Q2. When the input voltage to the divider reaches approximately 1.4 times the setting of the INPUT VOLTAGE switch, the current through the resistive string increases to 0.1 milliampere turning on Q2. Transistor Q2 turns on Q1 allowing capacitor C1 to discharge through the coil of relay K1 opening the input to the divider. Relay K1 is magnetically biased to remain in either the open or closed state until current flow through the coil is reversed. The operator may close the input to the divider by turning the INPUT VOLTAGE switch to RESET. This allows C202 to discharge in the opposite direction through the coil of K1 and also rapidly recharges C201 through R209. Operating power for the overvoltage circuit is furnished by two 6.75 volt mercury batteries.

SECTION IV

MAINTENANCE

4-1. INTRODUCTION

4-2. This section contains the instruction and information required for maintenance and calibration of the Model 750A Reference Divider. Because of the relative simplicity of the instrument and the critical nature of resistance matching and assembly processes, maintenance is limited in scope. When the instrument requires maintenance beyond that for which instructions are given in this manual, it should be returned to the factory for repair and recalibration.

4-3. TEST EQUIPMENT REQUIRED FOR MAINTENANCE

4-4. The test equipment required for maintenance is listed in Figure 4-1. Equivalent or similar units may be substituted for those listed providing they have the required specifications given in the figure.

4-5. PREVENTIVE MAINTENANCE

4-6. Preventive maintenance of the Model 750A consists of battery replacement, leakage testing, and clean-

ing. Batteries should be replaced annually. The frequency with which leakage testing and cleaning should be performed depends upon the environment of the instrument. In an air conditioned standards laboratory, there will be little contamination of surfaces within the instrument and therefore leakage testing and cleaning will seldom be required. In a contaminated atmosphere leakage testing and cleaning will be required frequently to maintain the accuracy of the instrument.

4-7. BATTERY REPLACEMENT

4-8. The overvoltage trip circuit is powered by two 6.75 volt mercury cells which should be replaced annually. They are located inside a cover on the rear panel of the instrument as shown in Figure 4-2. To replace the cells proceed as follows:

- a. Using a screwdriver turn the two battery cover fasteners one-quarter turn counterclockwise.
- b. Lift the cover off.
- c. Pull the two cells from their clips.

RECOMMENDED EQUIPMENT	SPECIFICATIONS REQUIRED
Voltage source; Fluke Model 332B or Fluke Model 412B	Voltage source of 0 to 1100 vdc. Accuracy of 0.25%. Stability of 0.005% per hour.
DC Differential Voltmeter; Fluke Model 895A	1 microvolt resolution. 100 megohms input resistance.
Standard Divider; Fluke Model 720A	Ratio accuracy of at least 1 ppm. Ratio capability to 1.1.
Lead Compensator; Fluke Model 721A	Any commercial lead compensator is adequate.
DC Power Supply; Fluke Model 412B	Maximum output voltage of at least 1700 vdc.
Null Detector; Fluke Model 845AB	Sensitivity of at least 10 microvolts fullscale. Battery operation.

Figure 4-1. TEST EQUIPMENT REQUIRED FOR MAINTENANCE

- d. Place new cells in the clips.
- e. Replace the battery cover and secure it by turning the fasteners one-quarter turn clockwise.

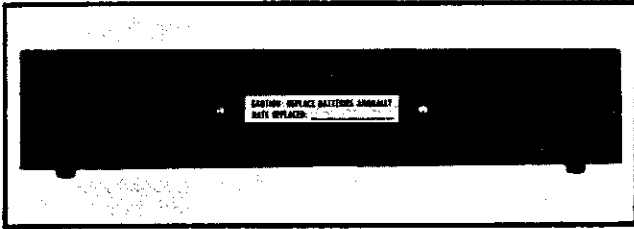

Figure 4-2. BATTERY LOCATION

4-9. LEAKAGE RESISTANCE TEST

4-10. The need for cleaning can be determined without removing the cover from the Model 750A by performing the simple test described in this paragraph. This test should be performed after cleaning to assure that all contamination has been removed. To measure leakage resistance, proceed as follows:

- a. Place the Model 750A on a sheet of dielectric.
- b. Use teflon insulated wire to connect the Model 750A, a 1000-volt source (Model 332B), and a null detector (Model 845AB) as shown in Figure 4-3.
- c. Connect a shunt resistor across the input of the null detector to bring its input resistance to 1 megohm on the 100 millivolt range. The value required for the Model 845AB is 1.1 megohms.
- d. Set the INPUT VOLTAGE switch to RESET.
- e. Turn on the 1000 volt supply and read the null detector. An indication of 10 millivolts corresponds to 10^{11} ohms. If the voltage indication is above 10 millivolts, the leakage resistance is too low and corrective measures must be taken. If repeated cleaning fails to correct the problem, troubleshooting must be undertaken.

4-11. CLEANING

4-12. When the Model 750A is properly cared for and kept in a controlled atmosphere, cleaning will seldom be required. However, any contamination, particularly oil, in the instrument can contribute to reduced leakage resistance which will impair accuracy. Cleanliness of the switches is critical because low leakage resistance between switch contacts shunts a part of the string. Dust may be removed with dry, oil free air at a pressure of 15 pounds per square inch or less. To remove oil, place the instrument on its side, place paper towels under it, and spray with freon TF degreasing agent.

4-13. CALIBRATION

4-14. GENERAL DISCUSSION

4-15. Calibration of the Model 750A is performed from the low end of the divider to the high end. Calibration adjustments are provided for the outputs 1.1

volt and above. If the 1.0 volt or a lower output is out of tolerance, the instrument must be used with a correction graph or it must be returned to the factory for replacement of the defective resistor. All calibration adjustments are located under the calibration access cover on the top of the instrument. To remove the cover, use a screwdriver to turn the two fasteners counterclockwise. All calibration adjustments are identified underneath the cover. The check procedures must be performed in order for accurate calibration of the instrument.

4-16. OVERVOLTAGE TRIP CHECK

- a. Set the INPUT VOLTAGE switch to RESET.
- b. Connect a dc voltmeter to the OUTPUT VOLTAGE binding posts and connect the calibrated power supply (Model 332B) to the INPUT VOLTAGE binding posts. Any Fluke dc voltmeter will serve for this check; it should be placed in TVM mode.
- c. Set both the INPUT VOLTAGE switch and the OUTPUT VOLTAGE switch to 1.1.
- d. Set the power supply to +17 volts and turn it on. The voltmeter should indicate +17 volts.

Note!

If the voltmeter indicates zero, set the INPUT VOLTAGE switch to RESET and then, back to 1.1. If the voltmeter still indicates zero, the overvoltage circuit has failed to close relay K1.

- e. Slowly increase the output voltage of the power supply until the overvoltage protection circuit trips. When the circuit trips, the voltmeter indication will drop to zero. The input voltage at this point should be between +18 and +22 volts.
- f. Repeat steps a through e for the remaining input voltage taps of the Model 750A. The switch positions and trip points are tabulated below.

INPUT VOLTAGE SETTING	OUTPUT VOLTAGE SETTING	INPUT VOLTAGE AT TRIP (Approximate)
5 volts	1.1 volts	18 to 22 volts
10 volts	1.1 volts	18 to 22 volts
50 volts	1.1 volts	69 to 83 volts
100 volts	1.1 volts	136 to 167 volts
500 volts	1.1 volts	640 to 780 volts
1000 volts	1.1 volts	1250 to 1530 volts
1100 volts	1.1 volts	1250 to 1530 volts

4-17. CALIBRATION CHECK OF 0.1, 0.5, AND 1 VOLT TAPS

- a. Connect the test equipment as shown in Figure 4-4. Use the 1.1 binding post on the standard divider (Model 720A).
- b. **HIGH LEAD BALANCE.** Balance lead and contact resistance on the high side of the dividers as follows:
 - (1) Set the standard divider to 1.099999X.
 - (2) Set the Model 750A INPUT VOLTAGE switch and the OUTPUT VOLTAGE switch to 1.1.
 - (3) Set the voltage source to 10.99999X volts.
 - (4) Set the lead compensator (Model 721A) to R STD > R TEST.

Note!

The null detector should be operated on battery power for all calibration checks and adjustment procedures.

- (5) Adjust the lead compensator high balance to obtain a null indication on the 10 microvolt range of the null detector (Model 845AB) microvolt range.
 - (6) Set the low balance of the lead compensator to the same setting as the high balance and recheck the null.
 - (7) Turn the VOLTAGE switch of the lead compensator to off.
- c. **LOW LEAD BALANCE.** Balance the lead and contact resistance on the low side of the divider as follows:
 - (1) Move the lead from the red OUTPUT VOLTAGE binding post to the black OUTPUT VOLTAGE binding post.
 - (2) Set the standard divider to 0.000000.
 - (3) Adjust the lead compensator low balance to obtain a null indication on the 10 microvolt range of the null detector.

d. CALIBRATION CHECK OF 0.1 VOLT TAP.

- (1) Move the lead from the black OUTPUT VOLTAGE binding post to the red OUTPUT VOLTAGE binding post.
- (2) Set the OUTPUT VOLTAGE switch to 0.1.
- (3) Set the standard divider to .1000000.

- (4) Observe the null detector; it should indicate null ± 10 microvolts. If the indication is beyond this tolerance, the instrument should be returned

to the factory for repair or a correction graph should be constructed.

Note!

One microvolt is equal to 1 ppm.

e. CALIBRATION CHECK OF 0.5 VOLT TAP.

- (1) Set the standard divider to .5000000.
- (2) Set the OUTPUT VOLTAGE switch to 0.5.
- (3) Observe the null detector; it should indicate null ± 50 microvolts. If the indication is beyond this tolerance, the instrument should be returned to the factory for repair or a correction graph should be constructed.

Note!

Five microvolts equal 1 ppm.

f. CALIBRATION CHECK OF 1 VOLT TAP.

- (1) Set the standard divider to 1.0000000.
- (2) Set the OUTPUT VOLTAGE switch to 1.0.
- (3) Observe the null detector; it should indicate null ± 100 microvolts. If the indication is beyond this tolerance, the instrument should be returned to the factory for repair or a correction graph should be prepared.

Note!

10 microvolts equal 1 ppm.

4-18. CALIBRATION OF THE STANDARD CELL OUTPUT AND 1.1 VOLT TAPS.

- a. Move the lead from the red OUTPUT VOLTAGE binding post to the red NULL DETECTOR binding post.
- b. Set the STANDARD CELL VOLTAGE dials to 1.018000.
- c. Set the standard divider to 1.0180000.
- d. Adjust R87 to obtain a null indication.

4-19. CALIBRATION OF THE 5, 10, 50, 100, 500, 1000, AND 1100 VOLT TAPS.

- a. Move the lead from the red NULL DETECTOR binding post to the red OUTPUT VOLTAGE binding post.
- b. **HIGH LEAD BALANCE.** Balance lead resistance on the high side of the dividers, before calibrating each tap, as follows:
 - (1) Set the Model 750A INPUT VOLTAGE and OUTPUT VOLTAGE switches to the tap being calibrated.

- (1) Set the Model 750A INPUT VOLTAGE and OUTPUT VOLTAGE switches to the tap being calibrated.

ON THE 750A

ALLOW TIME TO SETTLE

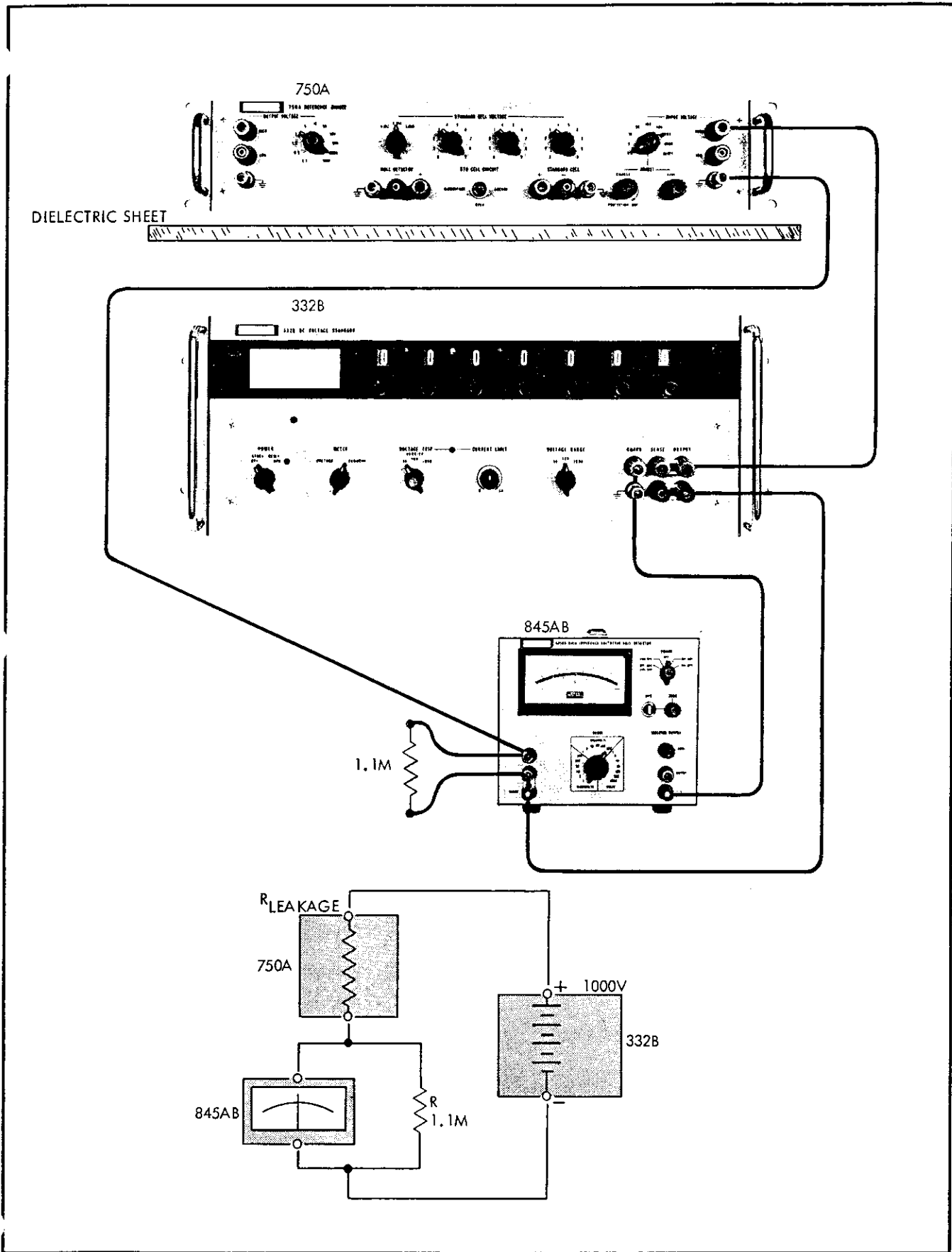

Figure 4-3. EQUIPMENT CONNECTIONS FOR LEAKAGE RESISTANCE TEST

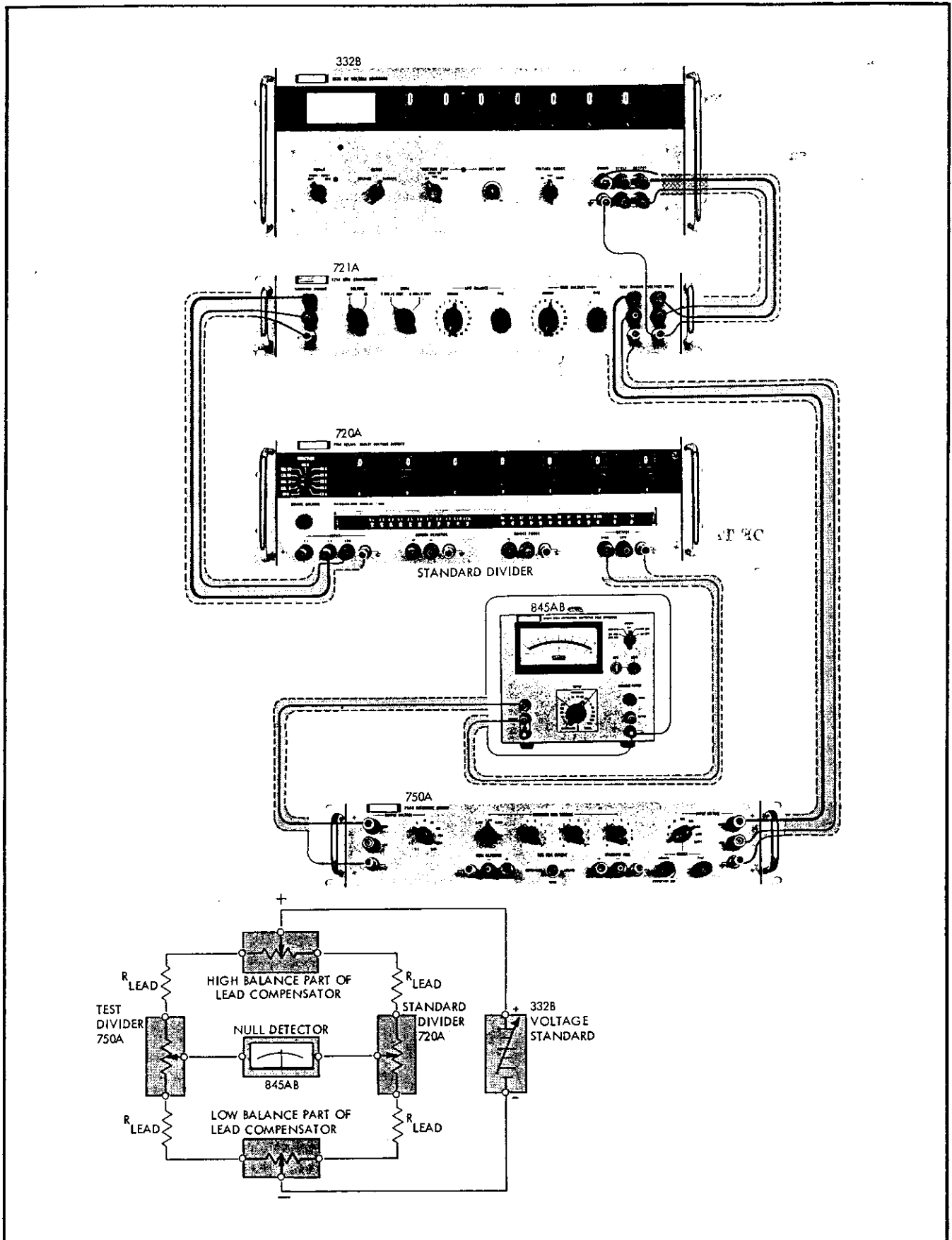

Figure 4-4. EQUIPMENT CONNECTIONS FOR CALIBRATION

- (2) Use the 1.0 input binding post on the standard divider except when calibrating the 1100 volt tap.
 - (3) Set the standard divider to .999999X.
 - (4) Set the voltage source to the output voltage given in Figure 4-5.
 - (5) On the lead compensator, set the mode switch to the position listed in Figure 4-5 and turn the voltage switch on.
 - (6) Adjust the high balance controls to obtain a null indication on the null detector.
- c. **LOW LEAD BALANCE.** Balance lead resistance on the low side of the dividers before calibrating each tap, as follows:
- (1) Move the lead from the red OUTPUT VOLTAGE binding post to the black OUTPUT VOLTAGE binding post.
 - (2) Set the standard divider output to .0000000.
 - (3) Adjust the low balance controls to obtain a null indication on the null detector.
- d. **CALIBRATION OF TAPS.**
- (1) Set the INPUT VOLTAGE switch to 5.
 - (2) Set the OUTPUT VOLTAGE switch to 1.1.
 - (3) Set the mode switch of the lead compensator to $R_{STD} > R_{TEST}$.
 - (4) Set the voltage source to 5 volts.
 - (5) Adjust high lead balance and low lead balance using the procedures given in paragraphs b and c.
 - (6) Adjust R34 to obtain an indication of null ± 1.1 microvolts.

Note!

To calibrate the remaining taps, refer to the information given in Figure 4-5 for steps d through j and use the procedure given in (1) through (6) of d above.

4-20. TROUBLESHOOTING

4-21. The following paragraphs describe the procedures to be followed if troubles develop in the Model 750A Reference Divider. Sufficient information is given to determine the nature of the trouble and whether the repair should be performed in the field or the instrument should be returned to the manufacturer for repair. Electrical components in the standard cell voltage circuit may be replaced in the field using parts ordered from the manufacturer. The variable trimmer resistors in the main divider string may be replaced in the field. Fixed resistors housed in the oil-filled can and factory selected fixed resistors should be replaced only by the manufacturer.

4-22. CHECKING THE MAIN DIVIDER STRING

4-23. Trouble in the main divider string may be localized to a particular step by utilizing the calibration procedure to check linearity. When the trouble has been localized, repair efforts should be confined to checking and replacing the variable trimmer resistor. If another resistor in the string is faulty, the instrument should be returned to the factory for repair and recalibration. To troubleshoot the main divider string proceed as follows:

- a. Perform the calibration checks described in paragraph 4-17. Inability to obtain a reading within the stated tolerance for any of these checks indicates the need for factory maintenance.
- b. Perform the tap calibration procedure described in paragraph 4-24. Each tap should be within 1 ppm of the correct value. If any tap is beyond this limit, a resistor in the step is defective. The variable trimmer resistor should be checked and replaced if defective. If a fixed resistor is defective the instrument should be returned to the factory for repair.

4-25. CHECKING THE STANDARD CELL VOLTAGE CIRCUIT

4-26. The source of trouble in the standard cell voltage circuit (a modified Kelvin-Varley divider) may be located easily by a simple linearity check. This check will locate the trouble to a particular defective resistor or switch contact. If used analytically, it will reveal whether the trouble in a faulty resistor is value change, open circuit, or short circuit. Referring to the schematic diagram will aid in understanding the procedure and analyzing the results. To check the standard cell voltage circuit, proceed as follows:

- a. Turn the INPUT VOLTAGE switch to RESET.
- b. Set the voltage source (Model 332B) to 11.00000 volts.
- c. Connect the voltage source to the OUTPUT VOLTAGE terminals, turn the OUTPUT VOLTAGE switch to 1.1, and turn the voltage source on.
- d. Connect the differential voltmeter (Model 895A) between the positive (red) NULL DETECTOR terminal and the negative (black) STANDARD CELL terminals.
- e. Turn the STANDARD CELL VOLTAGE controls to 1.017000. The differential voltmeter should read 10.17000 volts.
- f. Observe the differential voltmeter and advance the right hand control switch one position at a time. The measured voltage should increase 10 microvolts for each step.

Note!

If all steps are equal but low (under 10 uv), the shunt R1124 is under value or shorted.

In this case, the voltage measured in step e will be a few microvolts high. If all steps are equal but high (over 10 uv), the shunt R1124 is over value or open. In this case, the voltage measured in step e will be a few microvolts low. If all steps are 10 microvolts low. If all steps are 10 microvolts and equal but one is missing, the switch contact is open. An over value resistor will produce a high step (over 10 uv) and slightly reduce all other steps. An under value resistor will produce a low step (under 10 uv) and slightly increase all other steps. A shorted resistor will cause two successive steps to produce the same output and will increase all other steps by approximately one microvolt. An open resistor will cause an abrupt discontinuity with the voltage remaining constant up to the open resistor. As the open resistor is passed, the voltage will increase and remain constant but high for the remaining steps.

- g. Return the right hand dial to zero and advance the next control switch to the left, one position at a time. The measured voltage should increase 100 microvolts for each step.

Note!

If all steps are equal but low (under 100 uv), the shunt R1112 is under value or shorted. In this case, the voltage measured in step e will be a few microvolts high. If all steps are equal but high (over 100 uv), the shunt R1112 is over value or open. In this case, the voltage measured in step e will be a few microvolts low. If all steps are 100 microvolts and equal but one is missing the switch contact is open. An over value resistor will produce two adjacent high steps and slightly reduce all other steps. An under value resistor will produce two adjacent low steps and slightly increase all other steps. A shorted resistor will produce two successive low steps of approximately 50 microvolts and increase all other steps by about six microvolts. An open resistor will produce a constant but high voltage up to the open resistor. When the open resistor is shunted by the switch, the output voltage will drop to near normal (about 2 or 3 uv low). As the open resistor is passed, the voltage will rise to a slightly higher value than before and remain constant for the remaining steps.

- h. Return the dial to zero and advance the next control switch to the left, one position at a time. The measured voltage should increase one millivolt for each step.

Note!

The analysis noted step f applies to the results obtained in step g because the switch configurations are the same. The shunt is

R1005. The voltage errors noted in step f will be 10 times as great for step g.

- i. Return the dial to zero and advance the left hand control switch to 1.018 and then to 1.019. The measured voltage should increase to 1.018000 volts and then to 1.019000 volts.

Note!

As the switch is advanced so the contacts span an open or over value resistor the measured voltage will be high. An open resistor in the string above the contacts will cause a reading of zero. An open resistor in the string below the contacts will cause a reading of 1.1 volts. An over value resistor above the contacts will cause a low reading. An over value resistor in the string below the contacts will cause a high reading. As the switch is advanced to span a shorted resistor the measured voltage will remain unchanged. As the switch is advanced to span an under value resistor the measured voltage will be low. An under value resistor in the string above the contacts will cause a high reading. An under value resistor in the string below the contacts will cause a low reading.

4-27. TROUBLES IN THE OVERVOLTAGE CIRCUIT

4-28. If trouble in the overvoltage circuit is suspected, the overvoltage trip check given in paragraph 4-16 should be performed. If operation is not satisfactory, check the batteries (BT1 and BT2) and relay K1. If the voltage of either battery is below 6.0 volts, both batteries should be replaced. To check the relay remove the batteries and furnish 5.5 volts to the coil first in one direction and then the other. The relay contacts should open when the voltage is applied on one direction and close when it is applied in the other. The contacts should remain in position (either open or closed) when the voltage is removed. Contact resistance should not exceed 130 milliohms. If the trouble is not caused by the batteries or relay K1, refer to the schematic diagram and theory of operation to troubleshoot the circuit.

4-29. REPAIR

4-30. In the event that a nonlinearity beyond the range of calibration adjustment is discovered in the main divider string, the following effort should be made to correct the fault. First, return the equipment to the condition in which the nonlinearity was discovered and recheck the measurement. Second, exercise the variable trimmer resistor which is the adjustment for that step by slowly sweeping it from one end of travel to the other. It should provide an adjustment range of approximately 20 microvolts at the 1.1 output tap. This procedure may clean the contacts of the trimmer resistor and correct the fault. If the adjustment range is insufficient or if meter deflection is erratic as the trimmer resistor is swept through its travel, it should be re-

placed. If the fault is found to be in one of the fixed resistors of the string, the instrument should be returned to the factory for repair and recalibration.

4-31. If a defective resistor is found in the standard cell circuit it may be replaced with a repair part ordered from the factory.

STEP	750A INPUT SWITCH SETTING	* 750A OUTPUT SWITCH SETTING	APPLIED VOLTAGE	LEAD COMPENSATOR MODE SWITCH POSITION	NULL ADJUSTMENT	NULL SENSITIVITY	STANDARD DIVIDER SETTING
d.	5	1.1	5v	RSTD > RTEST	R34	1.1 uv = 1 ppm	.2200000
e.	10	5	10v	RSTD > RTEST	R29	5 uv = 1 ppm	.5000000
f.	50	10	50v	RSTD > RTEST	R26	10 uv = 1 ppm	.2000000
g.	100	50	100v	RSTD > RTEST	R21	50 uv = 1 ppm	.5000000
h.	500	100	100v	RSTD < RTEST	R14	20 uv = 1 ppm	.2000000
i.	1000	500	100v	RSTD < RTEST	R11	50 uv = 1 ppm	.5000000
* j.	1100	1000	110v	RSTD < RTEST	R2	100 uv = 1 ppm	1.0000000

Figure 4-5. TAP CALIBRATION STEPS

✓
720A 1.099999X

* * NOTE: 750A OUTPUT SWITCH SETTING AND INPUT SWITCH SETTING
MUST BE THE SAME FOR HIGH LEAD BALANCE ADJUSTMENT.

SECTION V

LIST OF REPLACEABLE PARTS

5-1. INTRODUCTION

5-2. This section contains complete descriptions of those parts one might normally expect to replace during the life of the instrument. The first listing is a breakdown of all of the major assemblies in the instrument. Subsequent listings itemize the components in each assembly. Every listing is accompanied by an illustration identifying each component in the listing. Assemblies and subassemblies are identified by name in the parts list and by a ten digit stock number in the illustrations. Components are identified by the schematic diagram reference designation (e. g. R1, C107, DS1). Parts not appearing on the schematic diagram are numbered consecutively throughout the parts list with a whole number.

5-3. COLUMNAR INFORMATION

- a. The REF DESIG column indexes the item description to the associated illustration. In general the reference designations are listed under each assembly in alpha-numeric order. Subassemblies of minor proportions are sometimes listed with the assembly of which they are a part. In this case, the reference designations for the components of the subassembly may appear out of order.
- b. The DESCRIPTION column describes the salient characteristics of the component. Indention of the description indicates the relationship to other assemblies, components, etc. In many cases it is necessary to abbreviate in this column. For abbreviations and symbols used, see the following page.
- c. The ten-digit part number by which the item is identified at the John Fluke Mfg. Co. is listed in the STOCK NO. column. Use this number when ordering parts from the factory or authorized representatives.
- d. The Federal Supply Code for the item manufacturer is listed in the MFR column. An abbreviated list of Federal Supply Codes is included in the Appendix.
- e. The part number which uniquely identifies the item to the original manufacturer is listed in the MFR PART NO column. If a component must be ordered by description, the type number is listed.
- f. The TOT QTY column lists the total quantity of the item used in the instrument. Second and subsequent listing of the same item are referenced to the first listing with the abbreviation REF. In the case of optional subassemblies, plug ins, etc. that are not always part of the instrument, the TOT QTY column lists the total quantity of the item in that particular assembly.
- g. Entries in the REC QTY column indicate the recommended number of spare parts necessary to support one to five instruments for a period of two years. This list presumes an availability of common electronic parts at the maintenance site. For maintenance for one year or more at an isolated site, it is recommended that at least one of every part in the instrument be stocked.
- h. The USE CODE column identifies certain parts which have been added, deleted or modified during the production of the instrument. Each part for which a Use Code has been assigned may be identified with a particular instrument serial number by consulting the Serial Number Effectivity List at the end of the parts list. As Use Codes are added to the list, the TOT QTY column listings are changed to reflect the most current information. Sometimes when a part is changed, the new part can and should be used as a replacement for the original part. In this event a parenthetical note is added in the DESCRIPTION column.

5-4 HOW TO OBTAIN PARTS

5-5. Standard components have been used wherever possible. Standard components may be ordered directly from the manufacturer by using the manufacturer's part number, or parts may be ordered from the John Fluke Mfg. Co. factory or authorized representative by using the Fluke part number. In the event the part you order has been replaced by a new or improved part, the replacement will be accompanied by an explanatory note and installation instructions, if necessary.

5-6. To insure prompt and efficient handling of your order to the John Fluke Mfg. Co., Inc. please list the following information:

a. Quantity.

- b. FLUKE Stock Number.
- c. Description.
- d. Reference Designation.
- e. Instrument model and serial number.

For example; 1 each, 4707-171678, Resistor, 100 ohms, $\pm 0.01\%$, 1/2W, R1002 for 750A, s/n 123.

If you must order structural parts not listed in the parts list, describe the part as completely as possible. A sketch of the part showing its location to other parts of the instrument is usually most helpful.

5-7. LIST OF ABBREVIATIONS

ac	alternating current	mw	milliwatt
Al	Aluminum	na	nanoampere
amp	ampere	nsec	nanosecond
assy	assembly	nv	nanovolt
cap	capacitor	Ω	ohm
car flm	carbon film	ppm	parts per million
C	centigrade	piv	peak inverse voltage
cer	ceramic	p-p	peak to peak
comp	composition	pf	picofarad
conn	connector	plstc	plastic
db	decibel	p	pole
dc	direct current	pos	position
dpdt	double-pole, double-throw	P/C	printed circuit
dpst	double-pole, single-throw	rf	radio frequency
elect	electrolytic	rfi	radio frequency interference
F	fahrenheit	res	resistor
Ge	germanium	rms	root mean square
gmV	guaranteed minimum value	rtry	rotary
h	henry	sec	second
Hz	hertz	sect	section
hf	high frequency	S/N	serial number
IC	integrated circuit	Si	silicon
if	intermediate frequency	scr	silicon controlled rectifier
k	kilohm	spdt	single-pole, double-throw
kHz	kilohertz	spst	single-pole, single-throw
kv	kilovolt	sw	switch
lf	low frequency	Ta	tantalum
MHz	megahertz	tstr	transistor
M	megohm	tvm	transistor voltmeter
met flm	metal film	uhf	ultra high frequency
ua	microampere	vtvm	vacuum tube voltmeter
uf	microfarad	var	variable
uh	microhenry	vhf	very high frequency
usec	microsecond	vlf	very low frequency
uv	microvolt	v	volt
ma	milliampere	va	voltampere
mh	millihenry	vac	volts, alternating current
m	milliohms	vdc	volts, direct current
msec	millisecond	w	watt
mv	millivolt	ww	wire wound

REF DESIG	DESCRIPTION	STOCK NO	MFR	MFR PART NO	TOT QTY	REC QTY	USE CODE
	<p>FINAL ASSEMBLY-Figure 5-1</p> <p>Front Panel Assembly (See Figure 5-2)</p> <p>Chassis Assembly (See Figure 5-4)</p>	750A					

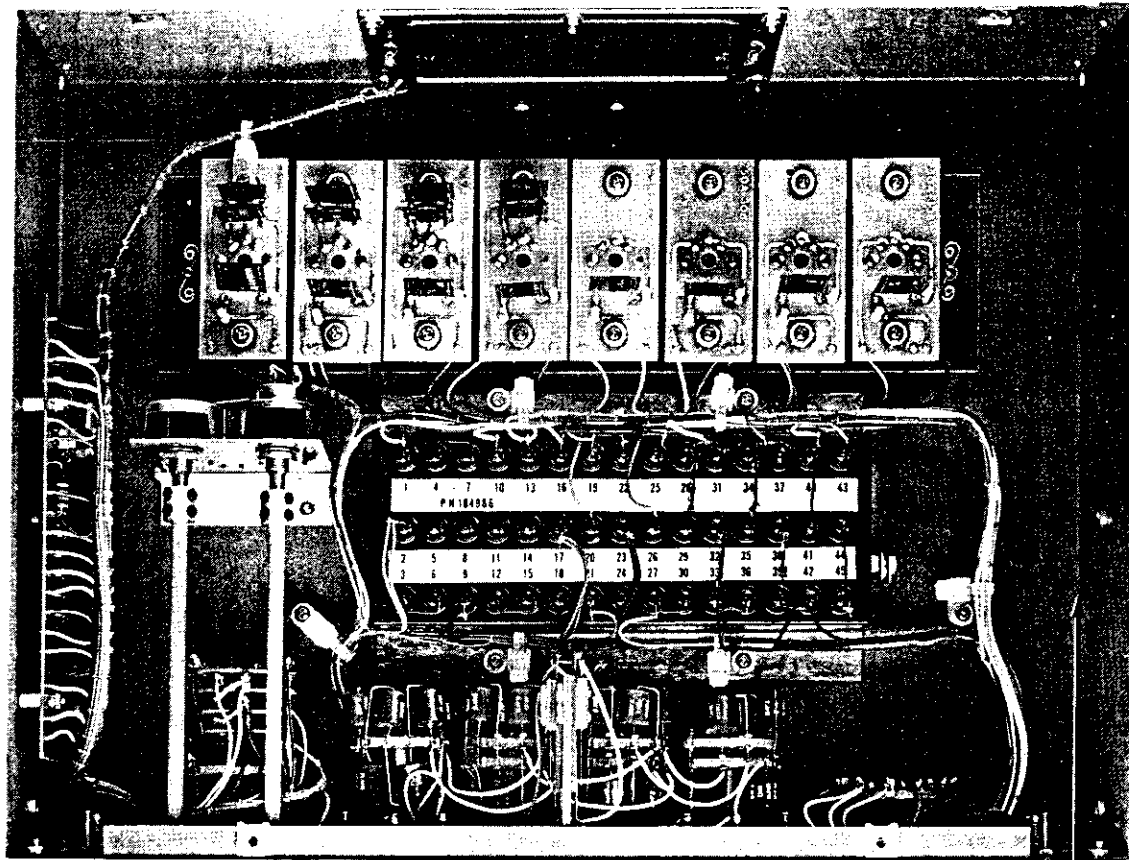

Front Panel Assembly

Chassis Assembly

Figure 5-1. FINAL ASSEMBLY

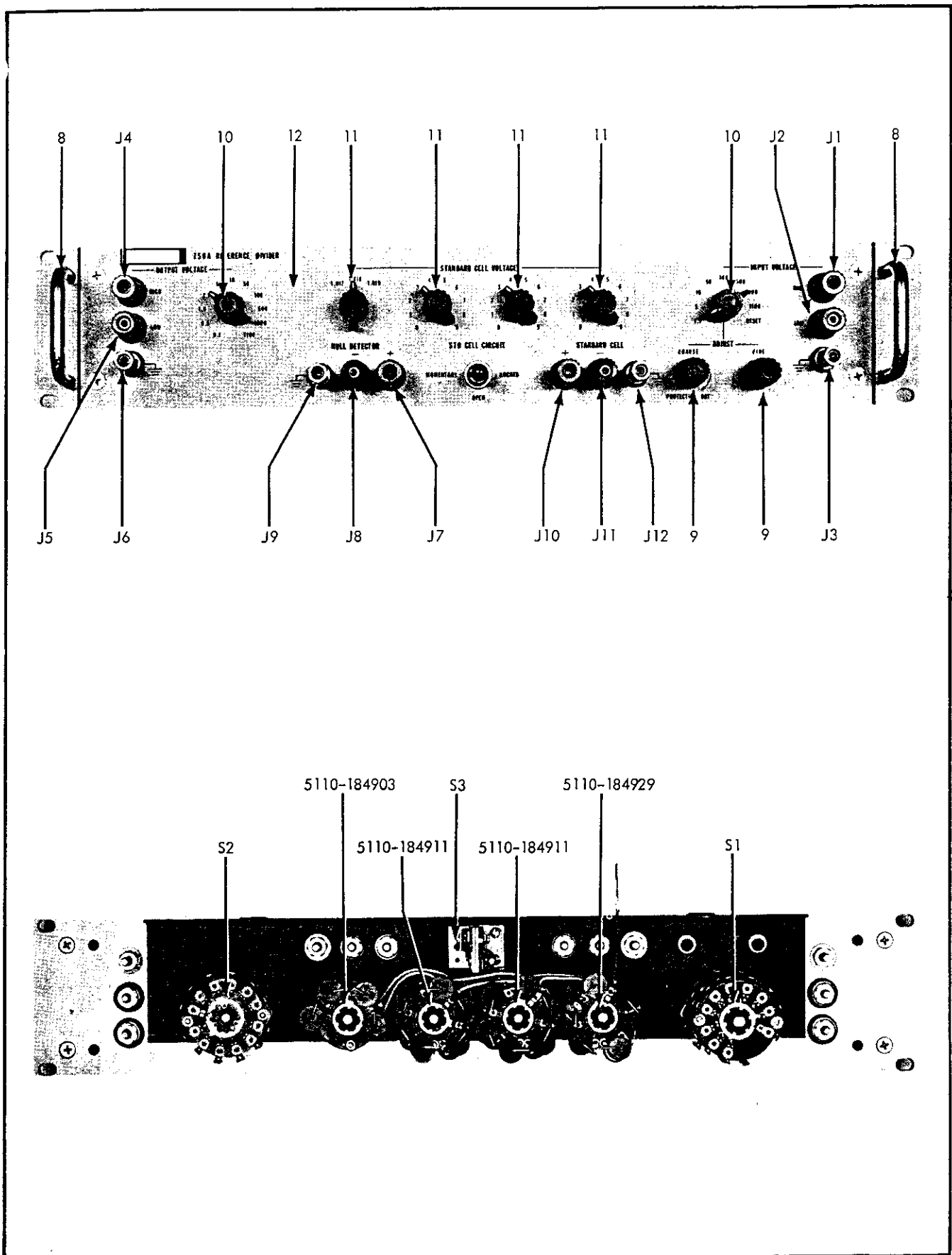

Figure 5-2. FRONT PANEL ASSEMBLY

REF DESIG	DESCRIPTION	STOCK NO	MFR	MFR PART NO	TOT QTY	REC QTY	USE CODE
	FRONT PANEL ASSEMBLY - Figure 5-2						
	Kelvin-Varley "A" Switch Assembly (See Figure 5-3)	5110-184903 (750A-410)	89536	5110-184903	1		
	Kelvin-Varley "B" Switch Assembly (See Figure 5-3)	5110-184911 (750A-411)	89536	5110-184911	2		
	Kelvin-Varley "C" Switch Assembly (See Figure 5-3)	5110-184911 (750A-411)	89536	5110-184911	REF		
	Kelvin-Varley "D" Switch Assembly (See Figure 5-3)	5110-184929 (750A-412)	89536	5110-184929	1		
J1	Binding post, red, Input	2811-149856	58474	BHB-10208-G22	4		
J2	Binding post, black, Input	2811-149864	58474	BHB-10208-G21	4		
J3	Binding post, ground	2811-155911	58474	GP30NC	4		
J4	Binding post, red, Output	2811-149856	58474	BHB-10208-G22	REF		
J5	Binding post, black, Output	2811-149864	58474	BHB-10208-G21	REF		
J6	Binding post, ground	2811-155911	58474	GP30NC	REF		
J7	Binding post, red, Standard Cell	2811-149856	58474	BHB-10208-G22	REF		
J8	Binding post, black, Standard Cell	2811-149864	58474	BHB-10208-G21	REF		
J9	Binding post, ground	2811-155911	58474	GP30NC	REF		
J10	Binding post, red, Null Detector	2811-149856	58474	BHB-10208-G22	REF		
J11	Binding post, black, Null Detector	2811-149864	58474	BHB-10208-G21	REF		
J12	Binding post, ground	2811-155911	58474	GP30NC	REF		
S1	Switch, INPUT, rotary, 5p, 9 pos, 5 sect	5105-184531	89536	5105-184531	1		
S2	Switch, OUTPUT, rotary, 1p, 11 pos, 1 sect	5105-184499	89536	5105-184499	1		
S3	Switch, STANDARD CELL, toggle, dpdt	5106-176594	82389	6S-2457	1		
8	Handle, chrome-plated brass	2404-100412	05704	825	2		
9	Knob, COARSE ADJUST, FINE ADJUST	2405-158949	89536	2405-158949	2		
10	Knob, INPUT VOLTAGE, OUTPUT VOLTAGE	2405-170050	89536	2405-170050	2		A
	KNOB, INPUT VOLTAGE, OUTPUT VOLTAGE	2405-158956	89536	2405-158956	6		B
11	Knob, STANDARD CELL VOLTAGE	2405-158956	89536	2405-158956	REF		
12	Panel, front	1406-184556	89536	1406-184556	1		

REF DESIG	DESCRIPTION	STOCK NO	MFR	MFR PART NO	TOT QTY	REC QTY	USE CODE
	KELVIN-VARLEY "A" SWITCH ASSEMBLY-Figure 5-3	5110-184903 (750A-410)	89536	5110-184903	REF		
R1001	Res, ww, 100Ω ±0.01%, 1/2w	4707-171678	89536	4707-171678	36	1	
R1002	Res, ww, 100Ω ±0.01%, 1/2w	4707-171678	89536	4707-171678	REF		
R1003	Res, ww, 100Ω ±0.01%, 1/2w	4707-171678	89536	4707-171678	REF		
R1004	Res, ww, 100Ω ±0.01%, 1/2w	4707-171678	89536	4707-171678	REF		
R1005	Res, ww, 250Ω ±0.01%, 1/2w	4707-182220	89536	4707-182220	3	1	
S1001	Switch, rotary, 2p, 3 pos, 2 sect	5105-184507	89536	5105-184507	1		
	KELVIN-VARLEY "B" SWITCH ASSEMBLY-Figure 5-3	5110-184911 (750A-411)	89536	5110-184911	REF		
R1101	Res, ww, 100Ω ±0.05%, 1/2w	4707-171678	89536	4707-171678	REF	1	
R1102	Res, ww, 100Ω ±0.05%, 1/2w	4707-171678	89536	4707-171678	REF		
R1103	Res, ww, 100Ω ±0.05%, 1/2w	4707-171678	89536	4707-171678	REF		
R1104	Res, ww, 100Ω ±0.05%, 1/2w	4707-171678	89536	4707-171678	REF		
R1105	Res, ww, 100Ω ±0.05%, 1/2w	4707-171678	89536	4707-171678	REF		
R1106	Res, ww, 100Ω ±0.05%, 1/2w	4707-171678	89536	4707-171678	REF		
R1107	Res, ww, 100Ω ±0.05%, 1/2w	4707-171678	89536	4707-171678	REF		
R1108	Res, ww, 100Ω ±0.05%, 1/2w	4707-171678	89536	4707-171678	REF		
R1109	Res, ww, 100Ω ±0.05%, 1/2w	4707-171678	89536	4707-171678	REF		
R1110	Res, ww, 100Ω ±0.05%, 1/2w	4707-171678	89536	4707-171678	REF		
R1111	Res, ww, 100Ω ±0.05%, 1/2w	4707-171678	89536	4707-171678	REF		
R1112	Res, ww, 250Ω ±0.05%, 1/2w	4707-182220	89536	4707-182220	REF	1	
S1101	Switch, rotary, 2p, 10 pos, 2 sect	5105-184515	89536	5105-184515	2		
	KELVIN-VARLEY "C" SWITCH ASSEMBLY-Figure 5-3	5110-184911 (750A-411)	89536	5110-184911	REF		
R1113	Res, ww, 100Ω ±0.05%, 1/2w	4707-171678	89536	4707-171678	REF		
R1114	Res, ww, 100Ω ±0.05%, 1/2w	4707-171678	89536	4707-171678	REF		
R1115	Res, ww, 100Ω ±0.05%, 1/2w	4707-171678	89536	4707-171678	REF		
R1116	Res, ww, 100Ω ±0.05%, 1/2w	4707-171678	89536	4707-171678	REF		
R1117	Res, ww, 100Ω ±0.05%, 1/2w	4707-171678	89536	4707-171678	REF		
R1118	Res, ww, 100Ω ±0.05%, 1/2w	4707-171678	89536	4707-171678	REF		
R1119	Res, ww, 100Ω ±0.05%, 1/2w	4707-171678	89536	4707-171678	REF		
R1120	Res, ww, 100Ω ±0.05%, 1/2w	4707-171678	89536	4707-171678	REF		
R1121	Res, ww, 100Ω ±0.05%, 1/2w	4707-171678	89536	4707-171678	REF		
R1122	Res, ww, 100Ω ±0.05%, 1/2w	4707-171678	89536	4707-171678	REF		
R1123	Res, ww, 100Ω ±0.05%, 1/2w	4707-171678	89536	4707-171678	REF		
R1124	Res, ww, 250Ω ±0.05%, 1/2w	4707-182220	89536	4707-182220	REF		
S1102	Switch, rotary, 2p, 10 pos, 2 sect	5105-184515	89536	5105-184515	REF		

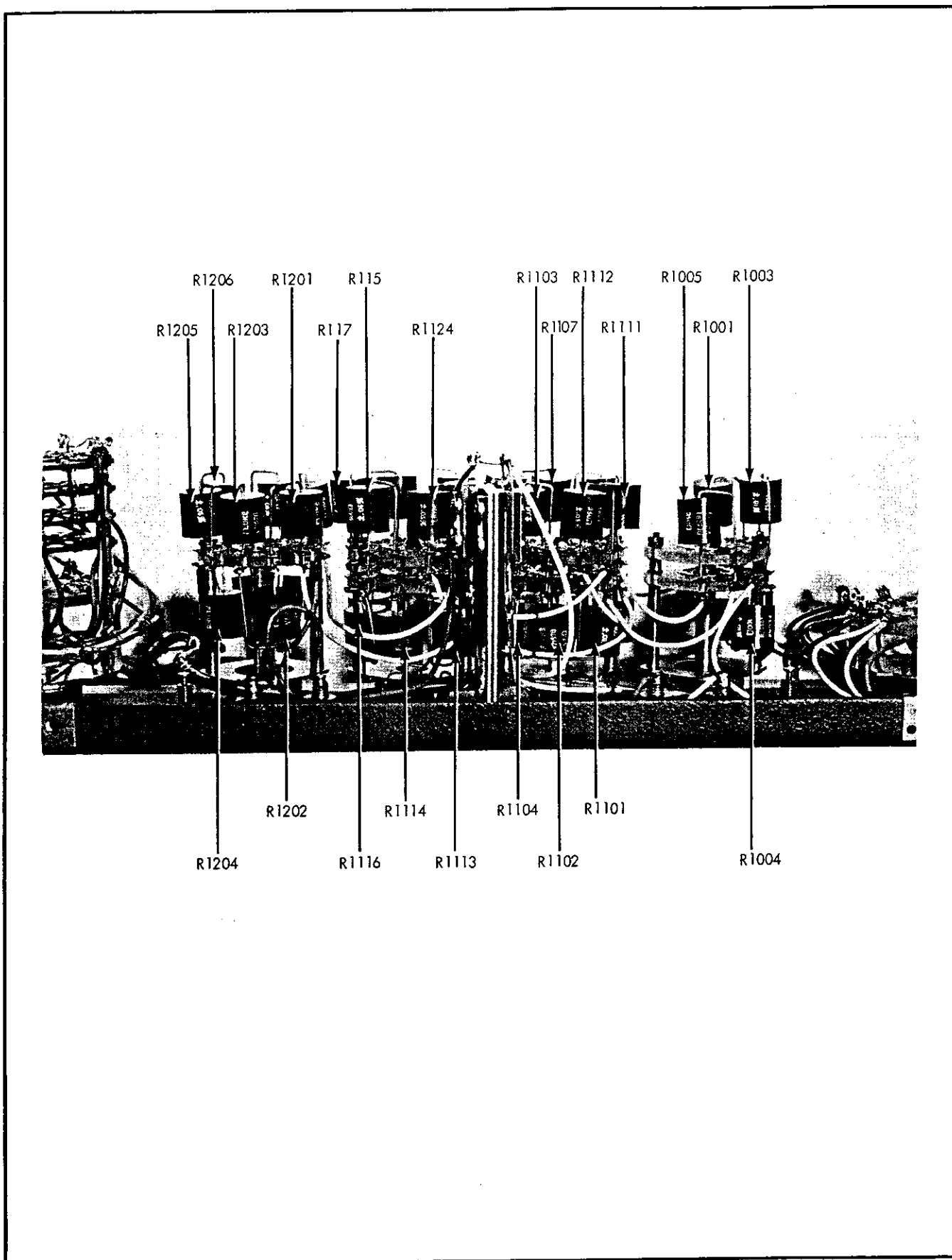

Figure 5-3. KELVIN-VARLEY SWITCH ASSEMBLIES (Sheet 1 of 2)

REF DESIG	DESCRIPTION	STOCK NO	MFR	MFR PART NO	TOT QTY	REC QTY	USE CODE
	KELVIN-VARLEY "D" SWITCH ASSEMBLY-Figure 5-3	5110-184929 (750A-412)	89536	5110-184929	REF		
R1201	Res, ww, 100Ω ±0.05%, 1/2w	4707-171678	89536	4707-171678	REF		
R1202	Res, ww, 100Ω ±0.05%, 1/2w	4707-171678	89536	4707-171678	REF		
R1203	Res, ww, 100Ω ±0.05%, 1/2w	4707-171678	89536	4707-171678	REF		
R1204	Res, ww, 100Ω ±0.05%, 1/2w	4707-171678	89536	4707-171678	REF		
R1205	Res, ww, 100Ω ±0.05%, 1/2w	4707-171678	89536	4707-171678	REF		
R1206	Res, ww, 100Ω ±0.05%, 1/2w	4707-171678	89536	4707-171678	REF		
R1207	Res, ww, 100Ω ±0.05%, 1/2w	4707-171678	89536	4707-171678	REF		
R1208	Res, ww, 100Ω ±0.05%, 1/2w	4707-171678	89536	4707-171678	REF		
R1209	Res, ww, 100Ω ±0.05%, 1/2w	4707-171678	89536	4707-171678	REF		
R1210	Res, ww, 100Ω ±0.05%, 1/2w	4707-171678	89536	4707-171678	REF		
S1201	Switch, rotary, 1p, 10 pos, 1 sect	5105-184523	89536	5105-184523	1		

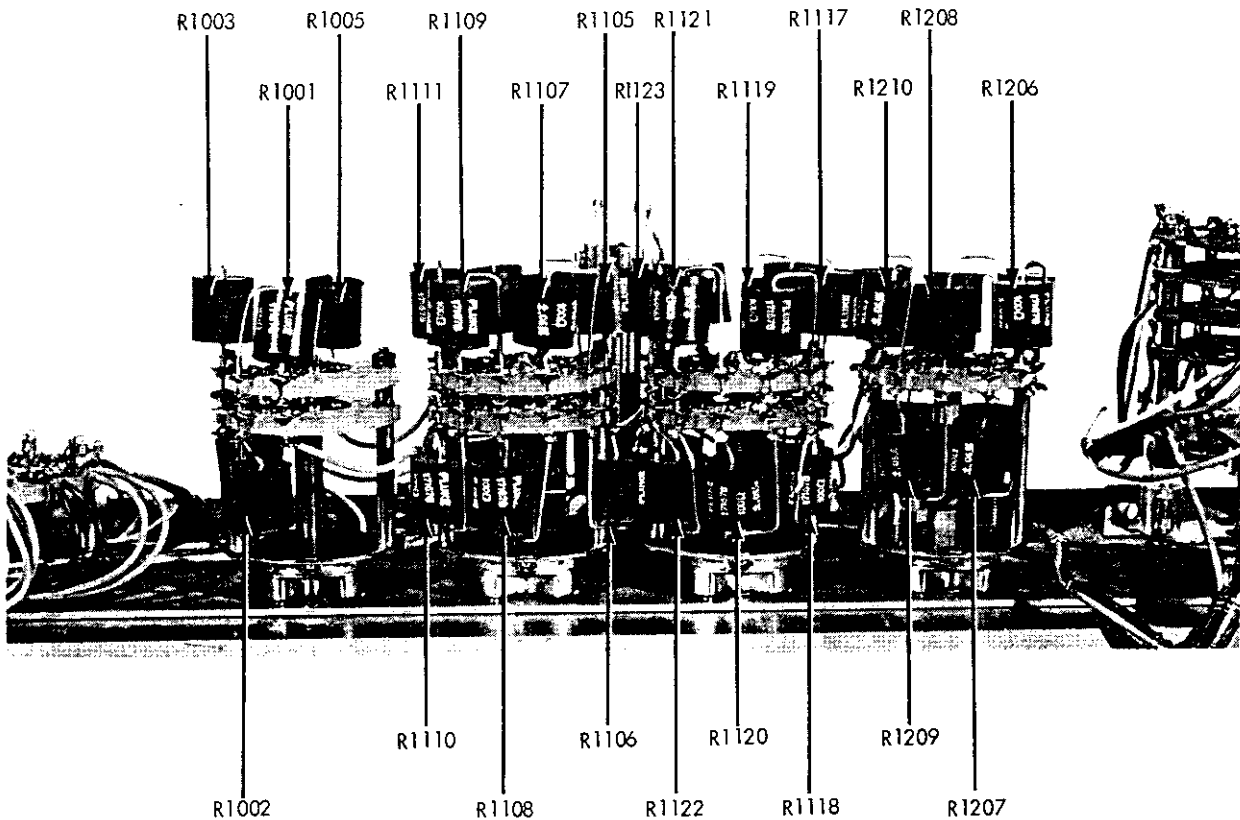

Figure 5-3. KELVIN-VARLEY SWITCH ASSEMBLIES (Sheet 2 of 2)

REF DESIG	DESCRIPTION	STOCK NO	MFR	MFR PART NO	TOT QTY	REC QTY	USE CODE
	CHASSIS ASSEMBLY-Figure 5-4						
	Adjustment No. 1 P/C Assembly (See Figure 5-5)	1702-184812 (750A-401)	89536	1702-184812	1		
	Adjustment No. 2 P/C Assembly (See Figure 5-5)	1702-184820 (750A-402)	89536	1702-184820	1		
	Adjustment No. 3 P/C Assembly (See Figure 5-5)	1702-184838 (750A-403)	89536	1702-184838	1		
	Adjustment No. 4 P/C Assembly (See Figure 5-5)	1702-184846 (750A-404)	89536	1702-184846	1		
	Adjustment No. 5 P/C Assembly (See Figure 5-5)	1702-184853 (750A-405)	89536	1702-184853	1		
	Adjustment No. 6 P/C Assembly (See Figure 5-5)	1702-184861 (750A-406)	89536	1702-184861	1		
	Adjustment No. 7 P/C Assembly (See Figure 5-5)	1702-184879 (750A-407)	89536	1702-184879	1		
	Adjustment No. 8 P/C Assembly (See Figure 5-5)	1702-184887 (750A-408)	89536	1702-184887	1		
	Protection P/C Assembly (See Figure 5-6)	1702-179416 (750A-409)	89536	1702-179416	1		
	Pot Mounting P/C Assembly (See Figure 5-7)	1702-184937 (750A-413)	89536	1702-184937	1		
	Resistor Can Assembly If a resistor in this assembly re- quires replacement, the entire instrument must be returned to the factory for repair and recal- ibration.	4710-184986 (750A-418)	89536	4710-184986	1		
BT1	Battery, 6.75v, Mercury (not illustrated)	4001-150409	37942	TR-135R	2		
BT2	Battery, 6.75v, Mercury (not illustrated)	4001-150409	37942	TR-135R	REF		
1	Case, battery	3155-184630	89536	3155-184630	1		
2	Coupler	2402-104505	89536	2402-104505	2		
3	Cover, battery	3156-184648	89536	3156-184648	1		
4	Cover, bottom	1403-184572	89536	1403-184572	1		
5	Cover, calibration adjustment (not illustrated)	3156-184622	89536	3156-184622	1		
6	Foot, rubber	2819-130138	89536	2819-130138	4		
7	Shaft, pot	2402-184689	89536	2402-184689	2		

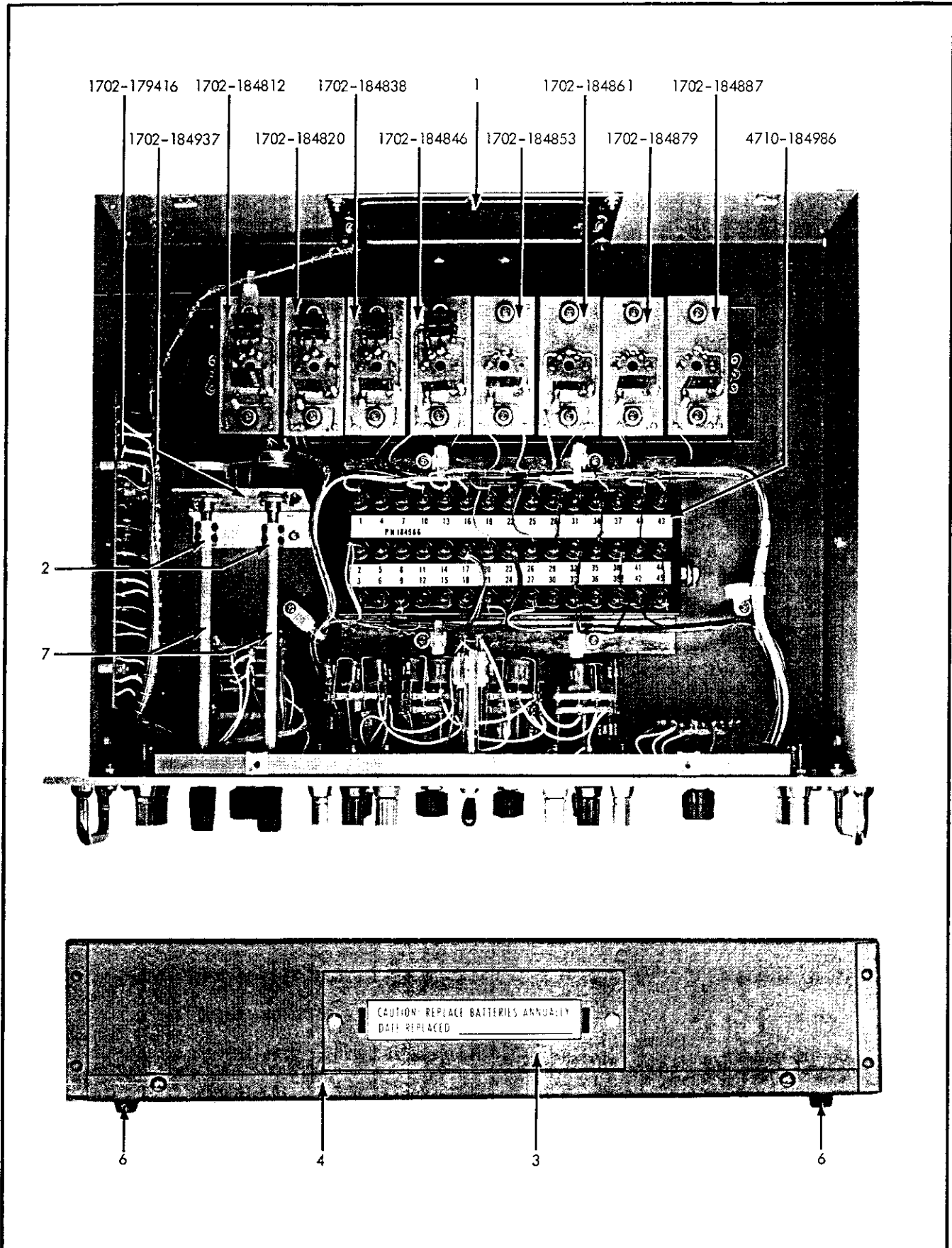











Figure 5-4. CHASSIS ASSEMBLY

REF DESIG	DESCRIPTION	STOCK NO	MFR	MFR PART NO	TOT QTY	REC QTY	USE CODE
	ADJUSTMENT NO. 1 P/C ASSEMBLY Figure 5-5	1702-184812 (750A-401)	89536	1702-184812	REF		
R47	Res, ww, factory selected						
R86	Res, ww, 10Ω ±0.09%, 1/2w	4707-155879	89536	4707-155879	3	1	
R87	Res, var, ww, 20Ω ±10%, 2w	4702-184457	71450	Type 115	4		
R88	Res, ww, 10Ω ±0.09%, 1/2w	4707-155879	89536	4707-155879	REF		
	ADJUSTMENT NO. 2 P/C ASSEMBLY Figure 5-5	1702-184820 (750A-402)	89536	1702-184820	REF		
R15	Res, ww, factory selected						
R33	Res, ww, 0.85Ω ±1%, 1/2w	4707-182378	89536	4707-182378	2	1	
R34	Res, var, ww, 2Ω ±10%, 2w	4702-153445	71450	Type 115	3		
R35	Res, ww, 2Ω ±0.1%, 1/2w	4707-131789	89536	4707-131789	1	1	
	ADJUSTMENT NO. 3 P/C ASSEMBLY Figure 5-5	1702-184838 (750A-403)	89536	1702-184838	REF		
R12	Res, ww, factory selected						
R28	Res, ww, 0.85Ω ±1%, 1/2w	4707-182378	89536	4707-182378	REF		
R29	Res, var, ww, 2Ω ±10%, 2w	4702-153445	71450	Type 115	REF		
R30	Res, ww, 1Ω ±1%, 1/2w	4707-131771	89536	4707-131771	2	1	
	ADJUSTMENT NO. 4 P/C ASSEMBLY Figure 5-5	1702-184846 (750A-404)	89536	1702-184846	REF		
R3	Res, ww, factory selected						
R25	Res, ww, 10Ω ±0.09%, 1/2w	4707-155879	89536	4707-155879	REF		
R26	Res, var, ww, 20Ω ±10%, 2w	4702-184457	71450	Type 115	REF		
R27	Res, ww, 20Ω ±0.03%, 1/2w	4707-155887	89536	4707-155887	1	1	

REF DESIG	DESCRIPTION	STOCK NO	MFR	MFR PART NO	TOT QTY	REC QTY	USE CODE
	ADJUSTMENT NO. 5 P/C ASSEMBLY Figure 5-5	1702-184853 (750A-405)	89536	1702-184853	REF		
R20	Res, ww, factory selected						
R21	Res, var, ww, $2\Omega \pm 10\%$, 2w	4702-153445	71450	Type 115	REF		
	ADJUSTMENT NO. 6 P/C ASSEMBLY Figure 5-5	1702-184861 (750A-406)	89536	1702-184861	REF		
R13	Res, ww, factory selected						
R14	Res, var, ww, $10\Omega \pm 10\%$, 2w	4702-183921	71450	Type 115	1		
	ADJUSTMENT NO. 7 P/C ASSEMBLY Figure 5-5	1702-184879 (750A-407)	89536	1702-184879	REF		
R10	Res, ww, factory selected						
R11	Res, var, ww, $20\Omega \pm 10\%$, 2w	4702-184457	71450	Type 115	REF		
	ADJUSTMENT NO. 8 P/C ASSEMBLY Figure 5-5	1702-184887 (750A-408)	89536	1702-184887	REF		
R1	Res, ww, factory selected						
R2	Res, var, ww, $20\Omega \pm 10\%$, 2w	4702-184457	71450	Type 115	REF		
 These resistors are factory selected. If replacement is required, give model, serial number, full reference designation, and all information stamped on the resistor.							

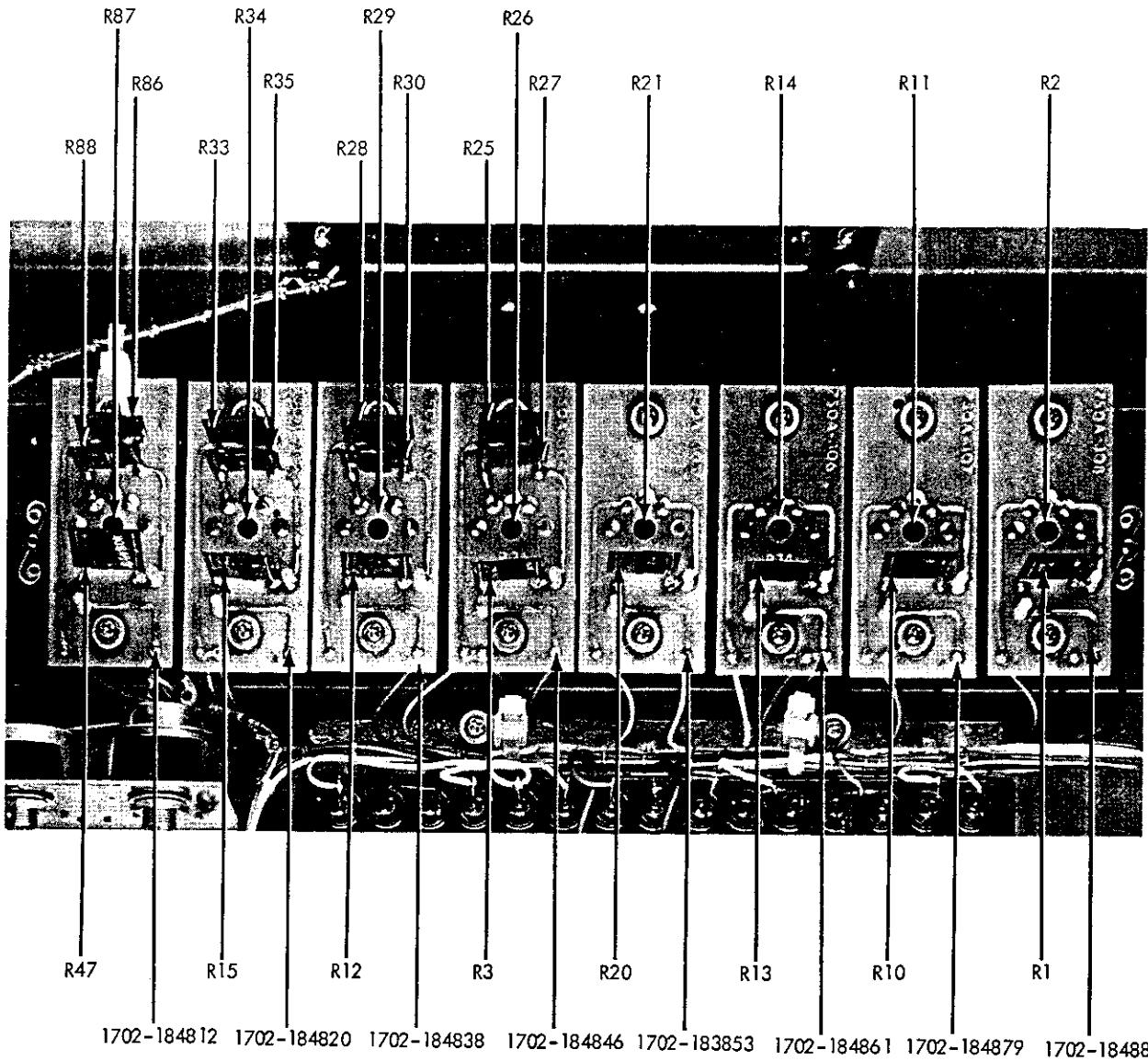

Figure 5-5. ADJUSTMENT P/C ASSEMBLIES NUMBER 1 THROUGH NUMBER 8

REF DESIG	DESCRIPTION	STOCK NO	MFR	MFR PART NO	TOT QTY	REC QTY	USE CODE
	PROTECTION P/C ASSEMBLY Figure 5-6	1702-179416 (750A-409)	89536	1702-179416	REF		
C201	Cap, Ta, 100 uf $\pm 10\%$, 10v	1508-170456	05397	K100C10K	2		
C202	Cap, Ta, 100 uf $\pm 10\%$, 10v	1508-170456	05397	K100C10K	REF		
C203	Cap, plstc, 0.47 uf $\pm 20\%$, 250v	1507-184366	73445	C280AE/P470K	1		
CR1	Diode, Type 1N4822	4802-112383	05277	1N4822	4	1	
CR2	Diode, Type 1N4822	4802-112383	05277	1N4822	REF		
CR3	Diode, Type 1N4822	4802-112383	05277	1N4822	REF		
CR4	Diode, Type 1N4822	4802-112383	05277	1N4822	REF		
K1	Relay, 6v, SPST	4501-185678	15636	R1407-1	1	1	
Q1	Tstr, Motorola Type MPS3638	4805-169375	04713	MPS3638	1	1	
Q2	Tstr, Type 2N3391	4805-168708	03508	2N3391	1	1	
R201	Res, comp, 6.8M $\pm 5\%$, 1w	4704-182311	01121	GB6855	1		
R202	Res, comp, 5.6M $\pm 5\%$, 1w	4704-182295	01121	GB5655	1		
R203	Res, comp, 750k $\pm 5\%$, 1w	4704-182329	01121	GB7545	1		
R204	Res, comp, 560k $\pm 5\%$, 1w	4704-182337	01121	GB5645	1		
R205	Res, comp, 120k $\pm 5\%$, 1w	4704-182303	01121	GB1245	1		
R206	Res, comp, 68k $\pm 10\%$, 1w	4704-109629	01121	GB6835	1		
R207	Res, comp, 560k $\pm 10\%$, 1/2w	4704-108795	01121	EB5645	1		
R208	Res, comp, 100k $\pm 5\%$, 1/2w	4704-168054	01121	EB1045	1		
R209	Res, comp, 1k $\pm 5\%$, 1/2w	4704-108597	01121	EB1025	1		

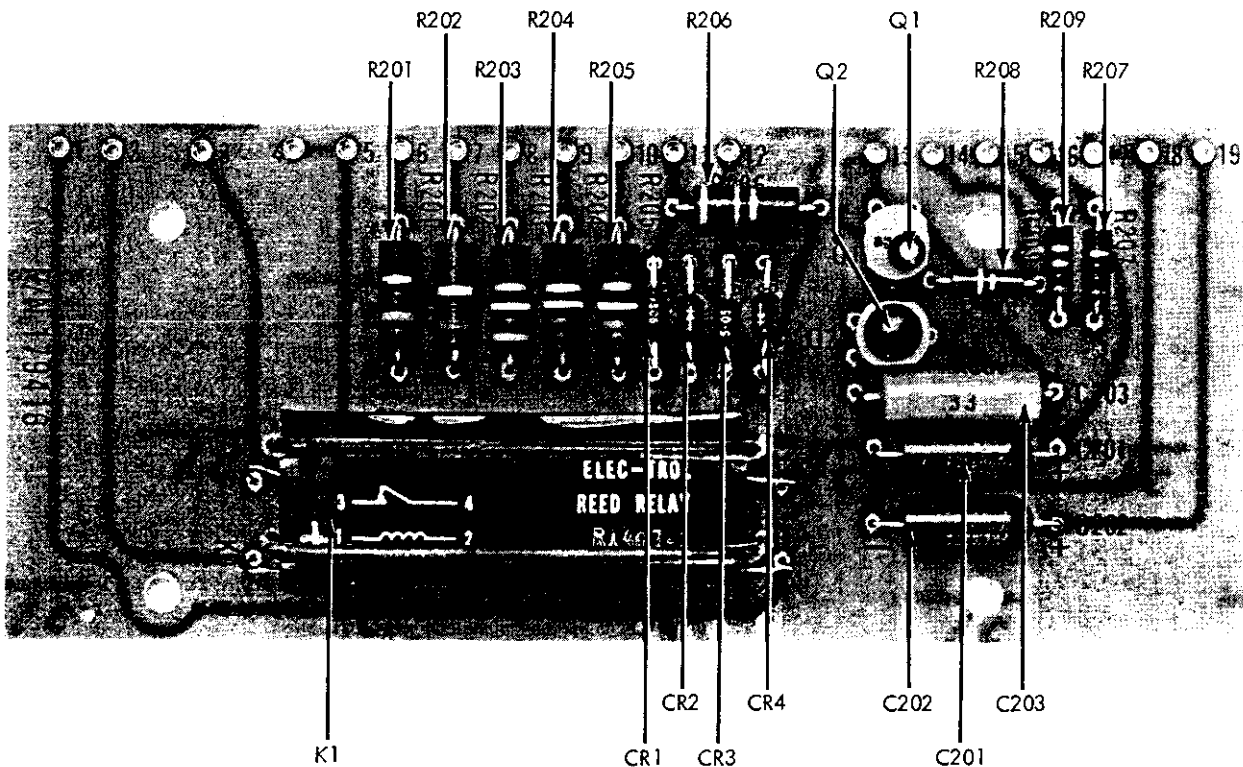

Figure 5-6. PROTECTION P/C ASSEMBLY

REF DESIG	DESCRIPTION	STOCK NO	MFR	MFR PART NO	TOT QTY	REC QTY	USE CODE
	POT MOUNTING P/C ASSEMBLY Figure 5-7	1702-184937 (750A-413)	89536	1702-184937	REF		
R101, S101	Res, var, ww, $10\Omega \pm 10\%$, 2w	4702-185660	71450	Type 252	1		
R102	Res, ww, $1\Omega \pm 1\%$, 1/2w	4707-131771	89536	4707-131771	REF		
R103	Res, var, ww, $1\Omega \pm 10\%$, 2w	4702-185652	71450	Type 2W	1		
R104	Res, ww, $3\Omega \pm 1\%$, 1/2w	4707-182402	89536	4707-182402	1	1	

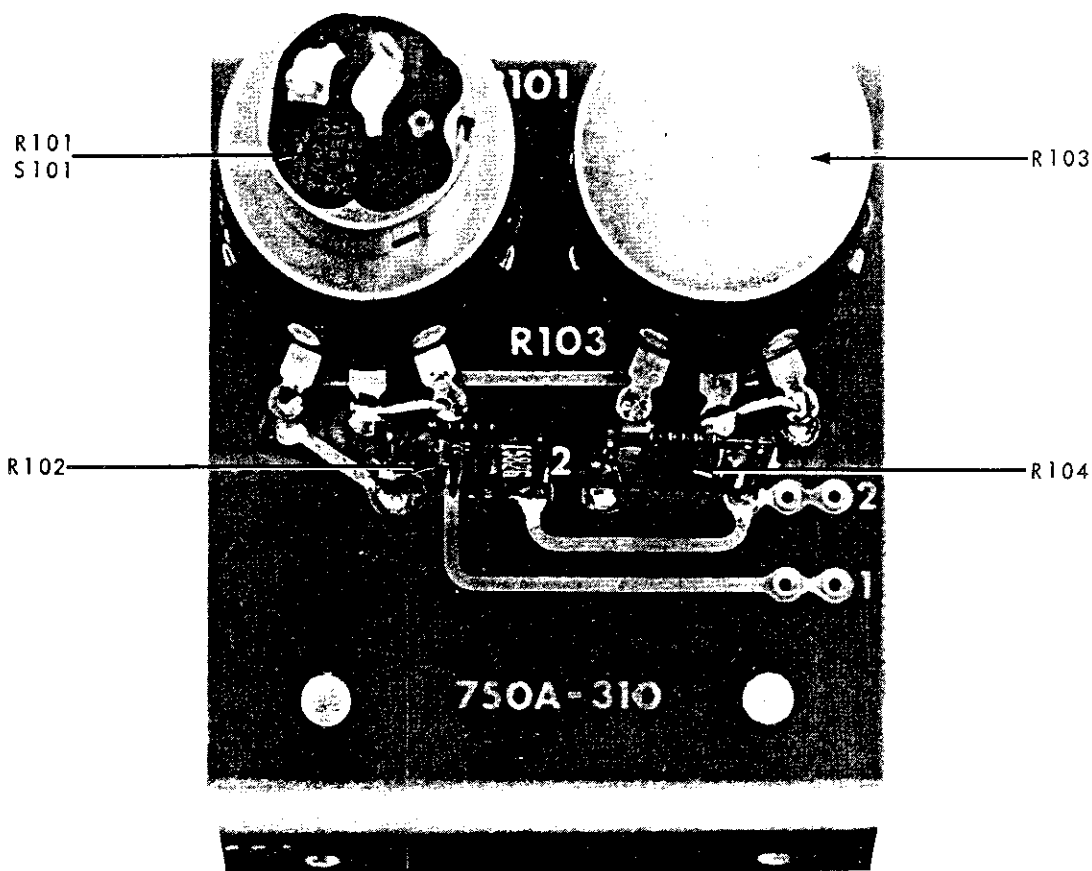

Figure 5-7. POT MOUNTING P/C ASSEMBLY

5-8. SERIAL NUMBER EFFECTIVITY

-9. A Use Code column is provided to identify certain parts that have been added, deleted, or modified during production of the Model 750A. Each part for which a use code has been assigned may be identified with a particular instrument serial number by consulting the Use Code Effectivity List below. All parts with no code are used on all instruments with serial numbers above 123. New codes will be added as required by instrument changes.

USE CODE	EFFECTIVITY
No	
Code	Model 750A serial number 123 and on.
A	Model 750A serial number 123 thru 217.
B	Model 750A serial number 218 and on.

Section 7

General Information

7-1. This section of the manual contains generalized user information as well as supplemental information to the List of Replaceable parts contained in Section 5. The following information is presented in this section:

List of Abbreviations

Federal Supply Codes for Manufacturers

Fluke Technical Service Centers — U.S. and Canada

Sales and Service Locations — International

Sales Representatives — U.S. and Canada

List of Abbreviations and Symbols

A or amp	ampere	H	henry	pF	picofarad
ac	alternating current	hd	heavy duty	pn	part number
af	audio frequency	hf	high frequency	(+) or pos	positive
a/d	analog-to-digital	Hz	hertz	pot	potentiometer
assy	assembly	IC	integrated circuit	p-p	peak-to-peak
AWG	american wire gauge	if	intermediate frequency	ppm	parts per million
B	bel	in	inch(es)	PROM	programmable read-only memory
bcd	binary coded decimal	intl	internal	psi	pound-force per square inch
°C	Celsius	I/O	input/output	RAM	random-access memory
cap	capacitor	k	kilo (10 ³)	rf	radio frequency
ccw	counterclockwise	kHz	kilohertz	rms	root mean square
cer	ceramic	kΩ	kilohm(s)	ROM	read-only memory
cermet	ceramic to metal(seal)	kV	kilovolt(s)	s or sec	second (time)
ckt	circuit	lf	low frequency	scope	oscilloscope
cm	centimeter	LED	light-emitting diode	SH	shield
cmrr	common mode rejection ratio	LSB	least significant bit	Si	silicon
comp	composition	LSD	least significant digit	serno	serial number
cont	continue	M	mega (10 ⁶)	sr	shift register
crt	cathode-ray tube	m	milli (10 ⁻³)	Ta	tantalum
cw	clockwise	mA	milliampere(s)	tb	terminal board
d/a	digital-to-analog	max	maximum	tc	temperature coefficient or temperature compensating
dac	digital-to-analog converter	mf	metal film	tcxo	temperature compensated crystal oscillator
dB	decibel	MHz	megahertz	tp	test point
dc	direct current	min	minimum	u or μ	micro (10 ⁻⁶)
dmm	digital multimeter	mm	millimeter	uhf	ultra high frequency
dvm	digital voltmeter	ms	millisecond	us or μs	microsecond(s) (10 ⁻⁶)
elect	electrolytic	MSB	most significant bit	uut	unit under test
ext	external	MSD	most significant digit	V	volt
F	farad	MTBF	mean time between failures	v	voltage
°F	Fahrenheit	MTTR	mean time to repair	var	variable
FET	Field-effect transistor	mV	millivolt(s)	vco	voltage controlled oscillator
ff	flip-flop	mv	multivibrator	vhf	very high frequency
freq	frequency	MΩ	megohm(s)	vlf	very low frequency
FSN	federal stock number	n	nano (10 ⁻⁹)	W	watt(s)
g	gram	na	not applicable	ww	wire wound
G	giga (10 ⁹)	NC	normally closed	xfmr	transformer
gd	guard	(-) or neg	negative	xstr	transistor
Ge	germanium	NO	normally open	xtal	crystal
GHz	gigahertz	ns	nanosecond	xtlo	crystal oscillator
gmV	guaranteed minimum value	opnl ampl	operational amplifier	Ω	ohm(s)
gnd	ground	p	pico (10 ⁻¹²)	μ	micro (10 ⁻⁶)
		para	paragraph		
		pcb	printed circuit board		

Federal Supply Codes for Manufacturers (Continued)

00213 Nytronics Comp. Group Inc. Subsidiary of Nytronics Inc. Formerly Sage Electronics Rochester, New York	03797 Eldema Div. Genisco Technology Corp. Compton, California	05574 Viking Industries Chatsworth, California	07597 Burndy Corp. Tape/Cable Div. Rochester, New York
00327 Welwyn International, Inc. Westlake, Ohio	03877 Transistron Electronic Corp. Wakefield, Massachusetts	05704 Replaced by 16258	07792 Lerma Engineering Corp. Northampton, Massachusetts
00656 Aerovox Corp. New Bedford, Massachusetts	03888 KDI Pyrofilm Corp. Whippany, New Jersey	05820 Wakefield Engineering Inc. Wakefield, Massachusetts	07910 Teledyne Semiconductor Formerly Continental Device Hawthorne, California
00686 Film Capacitors, Inc. Passaic, New Jersey	03911 Clairex Electronics Div. Clairex Corp. Mt. Vernon, New York	06001 General Electric Co. Electronic Capacitor & Battery Products Dept. Columbia, South Carolina	07933 - use 49956 Raytheon Co. Semiconductor Div. HQ Mountain View, California
00779 AMP Inc. Harrisberg, Pennsylvania	03980 Muirhead Inc. Mountainside, New Jersey	06136 Replaced by 63743	08225 Industro Transistor Corp. Long Island City, New York
01121 Allen-Bradley Co. Milwaukee, Wisconsin	04009 Arrow Hart Inc. Hartford, Connecticut	06383 Panduit Corp. Tinley Park, Illinois	08261 Spectra Strip Corp. Garden Grove, California
01281 TRW Electronic Comp. Semiconductor Operations Lawndale, California	04062 Replaced by 72136	06473 Bunker Ramo Corp. Amphenol SAMS Div. Chatsworth, California	08530 Reliance Mica Corp. Brooklyn, New York
01295 Texas Instruments, Inc. Semiconductor Group Dallas, Texas	04202 Replaced by 81312	06555 Beede Electrical Instrument Co. Penacook, New Hampshire	08806 General Electric Co. Miniature Lamp Products Dept. Cleveland, Ohio
01537 Motorola Communications & Electronics Inc. Franklin Park, Illinois	04217 Essex International Inc. Wire & Cable Div. Anaheim, California	06739 Electron Corp. Littleton, Colorado	08863 Nylomatic Corp. Norrisville, Pennsylvania
01686 RCL Electronics Inc. Manchester, New Hampshire	04221 Aemco, Div. of Midtex Inc. Mankato, Minnesota	06743 Clevite Corp. Cleveland, Ohio	08988 - use 53085 Skottie Electronics Inc. Archbald, Pennsylvania
01730 Replaced by 73586	04222 AVX Ceramics Div. AVX Corp. Myrtle Beach, Florida	06751 Components, Inc. Semcor Div. Phoenix, Arizona	09214 G.E. Co. Semi-Conductor Products Dept. Power Semi-Conductor Products OPN Sec. Auburn, New York
01884 - use 56289 Sprague Electric Co. Dearborn Electronic Div. Lockwood, Florida	04423 Telonic Industries Laguna Beach, California	06860 Gould Automotive Div. City of Industry, California	09353 C and K Components Watertown, Massachusetts
02114 Ferroxcube Corp. Saugerties, New York	04645 Replaced by 75376	06961 Vernitron Corp., Piezo Electric Div. Formerly Clevite Corp., Piezo Electric Div. Bedford, Ohio	09423 Scientific Components, Inc. Santa Barbara, California
02131 General Instrument Corp. Harris ASW Div. Westwood, Maine	04713 Motorola Inc. Semiconductor Products Phoenix, Arizona	06980 Eimac Div. Varian Associates San Carlos, California	09922 Burndy Corp. Norwalk, Connecticut
02395 Rason Mfg. Co. Brooklyn, New York	04946 Standard Wire & Cable Los Angeles, California	07047 Ross Milton, Co., The South Hampton, Pennsylvania	09969 Dale Electronics Inc. Yankton, S. Dakota
02533 Snelgrove, C.R. Co., Ltd. Don Mills, Ontario, Canada M3B 1M2	05082 Replaced by 94988	07115 Replaced by 14674	10059 Barker Engineering Corp. Formerly Amerace, Amerace ESNA Corp. Kenilworth, New Jersey
02606 Fenwal Labs Div. of Travenal Labs. Morton Grove, Illinois	05236 Jonathan Mfg. Co. Fullerton, California	07138 Westinghouse Electric Corp., Electronic Tube Division Horsehead, New York	11236 CTS of Berne Berne, Indiana
02660 Bunker Ramo Corp., Conn Div. Formerly Amphenol-Borg Electric Corp. Broadview, Illinois	05245 Components Corp. now Corcom, Inc. Chicago, Illinois	07233 TRW Electronic Components Cinch Graphic City of Industry, California	11237 CTS Keene Inc. Paso Robles, California
02799 Aero Capacitors, Inc. Chatsworth, California	05277 Westinghouse Electric Corp. Semiconductor Div. Youngwood, Pennsylvania	07256 Silicon Transistor Corp. Div. of BBF Group Inc. Chelmsford, MA	11358 CBS Electronic Div. Columbia Broadcasting System Newburyport, MN
03508 General Electric Co. Semiconductor Products Syracuse, New York	05278 Replaced by 43543	07263 Fairchild Semiconductor Div. of Fairchild Camera & Instrument Corp. Mountain View, California	11403 Best Products Co. Chicago, Illinois
03614 Replaced by 71400	05279 Southwest Machine & Plastic Co. Glendora, California	07344 Bircher Co., Inc. Rochester, New York	11503 Keystone Columbia Inc. Warren, Michigan
03651 Replaced by 44655	05397 Union Carbide Corp. Materials Systems Div. New York, New York		11532 Teledyne Relays Hawthorne, California

Federal Supply Codes for Manufacturers (Continued)

11711 General Instrument Corp Rectifier Division Hickville, New York	14099 Semtech Corp. Newbury Park, California	17069 Circuit Structures Lab. Burbank, California	24655 General Radio Concord, Massachusetts
11726 Qualidyne Corp. Santa Clara, California	14140 Edison Electronic Div. Mc Gray-Edison Co. Manchester, New Hampshire	17338 High Pressure Eng. Co., Inc. Oklahoma City, Oklahoma	24759 Lenox-Fugle Electronics Inc. South Plainfield, New Jersey
12014 Chicago Rivet & Machine Co. Bellwood, Illinois	14193 Cal-R-Inc. formerly California Resistor, Corp. Santa Monica, California	17545 Atlantic Semiconductors, Inc. Asbury Park, New Jersey	25088 Siemen Corp. Isilen, New Jersey
12040 National Semiconductor Corp. Danbury, Connecticut	14298 American Components, Inc. an Insilco Co. Conshohocken, Pennsylvania	17856 Siliconix, Inc. Santa Clara, California	25403 Amperex Electronic Corp. Semiconductor & Micro-Circuits Div. Statersville, Rhode Island
12060 Diodes, Inc. Chatsworth, California	14655 Cornell-Dublier Electronics Division of Federal Pacific Electric Co. Govt. Control Dept. Newark, New Jersey	17870 Replaced by 14140	27014 National Semiconductor Corp. Santa Clara, California
12136 Philadelphia Handle Co. Camden, New Jersey	14752 Electro Cube Inc. San Gabriel, California	18178 Vactec Inc. Maryland Heights, Missouri	27264 Molex Products Downers Grove, Illinois
12300 Potter-Brumfield Division AMF Canada LTD. Guelph, Onatrio, Canada	14869 Replaced by 96853	18324 Signetics Corp. Sunnyvale, California	28213 Minnesota Mining & Mfg. Co. Consumer Products Div. St. Paul, Minnesota
12323 Presin Co., Inc. Shelton, Connecticut	14936 General Instrument Corp. Semi Conductor Products Group Hicksville, New York	18612 Vishay Resistor Products Div. Vishay Intertechnology Inc. Malvern, Pennsylvania	28425 Serv-/Link formerly Bohannan Industries Fort Worth, Texas
12327 Freeway Corp. formerly Freeway Washer & Stamping Co. Cleveland, Ohio	15636 Elec-Trol Inc. Saugus, California	18927 G T E Sylvania Inc. Precision Material Group Parts Division Titusville, Pennsylvania	28478 Deltrol Controls Div. Deltrol Corporation Milwaukee, Wisconsin
12443 Budd Co. The, Polychem Products Plastic Products Div. Bridgeport, PA	15801 Fenwal Electronics Inc. Div. of Kidde Walter and Co., Inc. Framingham, Massachusetts	19451 Perine Machinery & Supply Co. Seattle, Washington	28480 Hewlett Packard Co. Corporate H.Q. Palo Alto, California
12615 U.S. Terminals Inc. Cincinnati, Ohio	15818 Teledyne Semiconductors, formerly Amelco Semiconductor Mountain View, California	19701 Electro-Midland Corp. Mepco-Electra Inc. Mineral Wells, Texas	28520 Heyman Mfg. Co. Kenilworth, New Jersey
12617 Hamlin Inc. Lake Mills, Wisconsin	15849 Litton Systems Inc. Useco Div. formerly Useco Inc. Van Nuys, California	20584 Enochs Mfg. Inc. Indianapolis, Indiana	29083 Monsanto, Co., Inc. Santa Clara, California
12697 Clarostat Mfg. Co. Dover, New Hampshire	15898 International Business Machines Corp. Essex Junction, Vermont	20891 Self-Organizing Systems, Inc. Dallas, Texas	29604 Stackpole Components Co. Raleigh, North Carolina
12749 James Electronics Chicago, Illinois	15909 Replaced by 14140	21604 Buckeye Stamping Co. Columbus, Ohio	30148 A B Enterprise Inc. Ahoskie, North Carolina
12856 Micrometals Sierra Madre, California	16258 Space-Lok Inc. Burbank, California	21845 Solitron Devices Inc. Transistor Division Riveria Beach, Florida	30323 Illinois Tool Works, Inc. Chicago, Illinois
12954 Dickson Electronics Corp. Scottsdale, Arizona	16299 Corning Glass Electronic Components Div. Raleigh, North Carolina	22767 ITT Semiconductors Palo Alto, California	31091 Optimax Inc. Colmar, Pennsylvania
12969 Unitrode Corp. Watertown, Massachusetts	16332 Replaced by 28478	23050 Product Comp. Corp. Mount Vernon, New York	32539 Mura Corp. Great Neck, New York
13103 Thermalloy Co., Inc. Dallas, Texas	16473 Cambridge Scientific Ind. Div. of Chemed Corporation Cambridge, Maryland	23732 Tracor Inc. Rockville, Maryland	32767 Griffith Plastic Corp. Burlingame, California
13327 Solitron Devices Inc. Tappan, New York	16742 Paramount Plastics Fabricators, Inc. Downey, California	23880 Stanford Applied Engrng. Santa Clara, California	32879 Advanced Mechanical Components Northridge, California
13511 Amphenol Cadre Div. Bunker-Ramo Corp. Los Gatos, California	16758 Delco Electronics Div. of General Motors Corp. Kokomo, Indiana	23936 Pamotor Div., Wm. J. Purdy Co. Burlingame, California	32897 Erie Technological Products, Inc. Frequency Control Div. Carlisle, Pennsylvania
13606 - use 56289 Sprague Electric Co. Transistor Div. Concord, New Hampshire	17001 Replaced by 71468	24248 Replaced by 94222	32997 Bourns Inc. Trimpot Products Division Riverside, California
13839 Replaced by 23732		24355 Analog Devices Inc. Norwood, Massachusetts	33173 General Electric Co. Products Dept. Owensboro, Kentucky

Federal Supply Codes for Manufacturers (Continued)

34333 Silicon General Westminister, California	70563 Amperite Company Union City, New Jersey	73293 Hughes Aircraft Co. Electron Dynamics Div. Torrence, California	77969 Rubbercraft Corp. of CA. LTD. Torrance, California
34335 Advanced Micro Devices Sunnyvale, California	70903 Belden Corp. Geneva, Illinois	73445 Amperex Electronic Corp. Hicksville, LI, New York	78189 Shakeproof Div. of Illinois Tool Works Inc. Elgin, Illinois
34802 Electromotive Inc. Kenilworth, New Jersey	71002 Birnbach Radio Co., Inc. Freeport, LI New York	73559 Carling Electric Inc. West Hartford, Connecticut	78277 Sigma Instruments, Inc. South Braintree, Massachusetts
37942 Mallory, P.R. & Co., Inc. Indianapolis, Indiana	71400 Bussmann Mfg. Div. of McGraw-Edison Co. Saint Louis, Missouri	73586 Circle F Industries Trenton, New Jersey	78488 Stackpole Carbon Co. Saint Marys, Pennsylvania
42498 National Radio Melrose, Massachusetts	71450 CTS Corp. Elkhart, Indiana	73734 Federal Screw Products, Inc. Chicago, Illinois	78553 Eaton Corp. Engineered Fastener Div. Tinnerman Plant Cleveland, Ohio
43543 Nytronics Inc. Transformer Co. Div. Geneva, New York	71468 ITT Cannon Electric Inc. Santa Ana, California	73743 Fischer Special Mfg. Co. Cincinnati, Ohio	79136 Waldes Kohinoor Inc. Long Island City, New York
44655 Ohmite Mfg. Co. Skokie, Illinois	71482 Clare, C.P. & Co. Chicago, Illinois	73899 JFD Electronics Co. Components Corp Brooklyn, New York	79497 Western Rubber Company Goshen, Indiana
49671 RCA Corp. New York, New York	71590 Centrelab Electronics Div. of Globe Union Inc. Milwaukee, Wisconsin	73949 Guardian Electric Mfg. Co. Chicago, Illinois	79963 Zierick Mfg. Corp. Mt. Kisko, New York
49956 Raytheon Company Lexington, Massachusetts	71707 Coto Coil Co., Inc. Providence, Rhode Island	74199 Quan Nichols Co. Chicago, Illinois	80031 Electro-Midland Corp., Mepco Div. A North American Phillips Co. Morristown, New Jersey
50088 Mostek Corp. Carrollton, Texas	71744 Chicago Miniature Lamp Works Chicago, Illinois	74217 Radio Switch Corp. Marlboro, New Jersey	80145 LFE Corp., Process Control Div. formerly API Instrument Co. Chesterland, Ohio
50579 Litronix Inc. Cupertino, California	71785 TRW Electronics Components Cinch Connector Operations Div. Elk Grove Village, Chicago, Illinois	74276 Signalite Div. General Instrument Corp. Neptune, New Jersey	80183 - use 56289 Sprague Products North Adams, Massachusetts
51605 Scientific Components Inc. Linden, New Jersey	72005 Driver, Wilber B., Co. Newark, New Jersey	74306 Piezo Crystal Co. Carlisle, Pennsylvania	80294 Bourns Inc., Instrument Div. Riverside, California
53021 Sangamo Electric Co. Springfield, Illinois	72092 Replaced by 06980	74542 Hoyt Elect. Instr. Works Penacook, New Hampshire	80583 Hammartund Mfg. Co., Inc. Red Bank, New Jersey
54294 Cutler-Hammer Inc. formerly Shallcross, A Cutter-Hammer Co. Selma, North Carolina	72136 Electro Motive Mfg. Co. Williamantic, Connecticut	74970 Johnson E.F., Co. Waseca, Minnesota	80640 Stevens, Arnold Inc. South Boston, Massachusetts
55026 Simpson Electric Co. Div. of Am. Gage and Mach. Co. Elgin, Illinois	72259 Nytronics Inc. Pelham Manor, New Jersey	75042 TRW Electronics Components IRC Fixed Resistors Philadelphia, Pennsylvania	81073 Grayhill, Inc. La Grange, Illinois
56289 Sprague Electric Co. North Adams, Massachusetts	72619 Dialight Div. Amperex Electronic Corp. Brooklyn, New York	75376 Kurz-Kasch Inc. Dayton, Ohio	81312 Winchester Electronics Div. of Litton Industries Inc. Oakville, Connecticut
58474 Superior Electric Co. Bristol, Connecticut	72653 G.C. Electronics Div. of Hydrometals, Inc. Brooklyn, New York	75378 CTS Knights Inc. Sandwich, Illinois	81439 Therm-O-Disc Inc. Mansfield, Ohio
60399 Torin Corp, formerly Torrington Mfg. Co. Torrington, Connecticut	72665 Replaced by 90303	75382 Kulka Electric Corp. Mount Vernon, New York	81483 International Rectifier Corp. Los Angeles, California
63743 Ward Leonard Electric Co., Inc. Mount Vernon, New York	72794 Dzus Fastener Co., Inc. West Islip, New York	75915 Littlefuse Inc. Des Plaines, Illinois	81590 Korry Mfg. Co. Seattle, Washington
64834 West Mfg. Co. San Francisco, California	72928 Gulton Ind. Inc. Gudeman Div. Chicago, Illinois	76854 Oak Industries Inc. Switch Div. Crystal Lake, Illinois	81741 Chicago Lock Co. Chicago, Illinois
65092 Weston Instruments Inc. Newark, New Jersey	72982 Erie Tech. Products Inc. Erie, Pennsylvania	77342 AMF Inc. Potter & Brumfield Div. Princeton, Indiana	82305 Palmer Electronics Corp. South Gate, California
66150 Winslow Tele-Tronics Inc. Eaton Town, New Jersey	73138 Beckman Instruments Inc. Helipot Division Fullerton, California	77638 General Instrument Corp. Rectifier Division Brooklyn, New York	82389 Switchcraft Inc. Chicago, Illinois
70485 Atlantic India Rubber Works Chicago, Illinois			

Federal Supply Codes for Manufacturers (Concluded)

82415 North American Phillips Controls Corp. Frederick, Maryland	88245 Litton Systems Inc. Useco Div. Van Nuys, California	91934 Miller Electric Co., Inc. Div of Aunet Woonsocket, Rhode Island	97966 Replaced by 11358
82872 Roanwell Corp. New York, New York	88419 Cornell-Dubilier Electronic Div. Federal Pacific Co. Fuquay-Varian, North Carolina	92194 Alpha Wire Corp. Elizabeth, New Jersey	98094 Replaced by 49956
82877 Rotron Inc. Woodstock, New York	88486 Plastic Wire & Cable Jewitt City, Connecticut	93332 Sylvania Electric Products Semiconductor Products Div. Woburn, Massachusetts	98159 Rubber-Teck, Inc. Gardena, California
82879 ITT Royal Electric Div. Pawtucket, Rhode Island	88690 Replaced by 04217	94145 Replaced by 49956	98278 Malco A Microdot Co., Inc. Connector & Cable Div. Pasadena, California
83003 Varo Inc. Garland, Texas	89536 Fluke, John Mfg. Co., Inc. Seattle, Washington	94154 - use 94988 Wagner Electric Corp. Tung-Sol Div. Newark, New Jersey	98291 Sealectro Corp. Mamaroneck, New York
83058 Carr Co., The United Can Div. of TRW Cambridge, Massachusetts	89730 G.E. Co., Newark Lamp Works Newark, New Jersey	94222 Southco Inc. formerly South Chester Corp. Lester, Pennsylvania	98388 Royal Industries Products Div. San Diego, California
83298 Bendix Corp. Electric Power Division Eatontown, New Jersey	90201 Mallory Capacitor Co. Div of P.R. Mallory Co., Inc. Indianapolis, Indiana	95146 Aico Electronic Products Inc. Lawrence, Massachusetts	98743 Replaced by 12749
83330 Smith, Herman H., Inc. Brooklyn, New York	90211 - use 56365 Square D Co. Chicago, Illinois	95263 Leecraft Mfg. Co. Long Island City, New York	98925 Replaced by 14433
83478 Rubbercraft Corp. of America, Inc. West Haven, Connecticut	90215 Best Stamp & Mfg. Co. Kansas City, Missouri	95264 Replaced by 98278	99120 Plastic Capacitors, Inc. Chicago, Illinois
83594 Burroughs Corp. Electronic Components Div. Plainfield, New Jersey	90303 Mallory Battery Co. Div. of Mallory Co., Inc. Tarrytown, New York	95275 Vitramon Inc. Bridgeport, Connecticut	99217 Bell Industries Elect. Comp. Div. formerly Southern Elect. Div. Burbank, California
83740 Union Carbide Corp. Battery Products Div. formerly Consumer Products Div. New York, New York	91094 Essex International Inc. Suglex/IWP Div. Newmarket, New Hampshire	95303 RCA Corp. Receiving Tube Div. Cincinnati, Ohio	99392 STM Oakland, California
84171 Arco Electronics Great Neck, New York	91293 Johanson Mfg. Co. Boonton, New Jersey	95348 Gordo's Corp. Bloomfield, New Jersey	99515 ITT Jennings Monrovia Plant Div. of ITT Jennings formerly Marshall Industries Capacitor Div. Monrovia, California
84411 TRW Electronic Components TRW Capacitors Ogallala, Nebraska	91407 Replaced by 58474	95354 Methode Mfg. Corp. Rolling Meadows, Illinois	99779 - use 29587 Bunker-Ramo Corp. Barnes Div. Landsdowne, Pennsylvania
84613 Fuse Indicator Corp. Rockville, Maryland	91502 Associated Machine Santa Clara, California	95712 Bendix Corp. Electrical Components Div. Microwave Devices Plant Franklin, Indiana	99800 American Precision Industries Inc. Delevan Division East Aurora, New York
84682 Essex International Inc. Industrial Wire Div. Peabody, Massachusetts	91506 Augat Inc. Attleboro, Massachusetts	95987 Weckesser Co. Inc. Chicago, Illinois	99942 Centrelab Semiconductor Centrelab Electronics Div. of Globe-Union Inc. El Monte, California
86577 Precision Metal Products, of Malden Inc. Stoneham, Massachusetts	91637 Dale Electronics Inc. Columbus, Nebraska	96733 San Fernando Electric Mfg. Co. San Fernando, California	Toyo Electronics (R-Ohm Corp.) Irvine, California
86684 Radio Corp. of America Electronic Components Div. Harrison, New Jersey	91662 Elco Corp. Willow Grove, Pennsylvania	96853 Gulton Industries Inc. Measurement and Controls Div. formerly Rustrak Instruments Co. Manchester, New Hampshire	National Connector Minneapolis, Minnesota
86928 Seastrom Mfg. Co., Inc. Glendale, California	91737 - use 71468 Gremar Mfg. Co., Inc. ITT Cannon/Gremar Santa Ana, California	96881 Thomson Industries, Inc. Manhasset, New York	
87034 Illuminated Products Inc. Subsidiary of Oak Industries Inc. Anahiem, California	91802 Industrial Devices, Inc. Edgewater, New Jersey	97540 Master Mobile Mounts Div. of Whitehall Electronics Corp. Ft. Meyers, Florida	
88219 Gould Inc. Industrial Div. Trenton, New Jersey	91833 Keystone Electronics Corp. New York, New York	97913 Industrial Electronic Hdware Corp. New York, New York	
	91836 King's Electronics Co., Inc. Tuckahoe, New York	97945 Penwalt Corp. SS White Industrial Products Div. Piscataway, New Jersey	
	91929 Honeywell Inc. Micro Switch Div. Freeport, Illinois		

Fluke Technical Service Centers — U.S. and Canada

United States	ILLINOIS	NEW JERSEY	Canada
<p>CALIFORNIA Burbank Fluke Technical Center 2020 N. Lincoln St. Zip: 91504 Tel. (213) 849-4641</p> <p>Santa Clara Fluke Technical Center 2300 Walsh Avenue Zip: 95050 Tel. (408) 985-1200</p> <p>COLORADO Denver Fluke Technical Center 1980 S. Quebec St. Unit 4 Zip: 80231 Tel. (303) 750-1228</p> <p>FLORIDA Orlando Fluke Technical Center 940 N. Fern Creek Ave. Zip: 32803 Tel. (305) 896-2296</p>	<p>Rolling Meadows Fluke Technical Center 1400 Hicks Road Zip: 60008 Tel. (312) 398-5800</p> <p>MARYLAND Kensington Fluke Technical Center 11501 Huff Court Zip: 20795 Tel. (301) 881-6155</p> <p>MASSACHUSETTS Waltham Fluke Technical Center 244 Second Ave. Zip: 02154 Tel. (617) 890-1604</p> <p>MINNESOTA Minneapolis Fluke Technical Center 10800 Lyndale Ave. So. Zip: 55420 Tel. (612) 884-4541</p>	<p>Clifton Fluke Technical Center 460 Colfax Ave. Zip: 07013 Tel. (201) 778-1339</p> <p>NORTH CAROLINA Greensboro Fluke Technical Center 1310 Beaman Place Zip: 27408 Tel. (919) 273-1918</p> <p>TEXAS Dallas Fluke Technical Center 14400 Midway Road Zip: 75240 Tel. (214) 233-9945</p> <p>WASHINGTON Mountlake Terrace John Fluke Mfg. Co., Inc. 21707 66th Ave. W. Suite 1 Zip: 98043 Tel. (206) 774-2206</p>	<p>ALBERTA Calgary Allan Crawford Assoc. Ltd. Fluke Technical Center 14-2280 39th N.E. Zip: T2E 6P7 Tel. (403) 276-9658</p> <p>ONTARIO Mississauga Allan Crawford Assoc. Ltd. Fluke Technical Center 6503 Northam Drive Zip: L4V 1J5 Tel. (416) 678-1500</p> <p>QUEBEC Longueuil Allan Crawford Assoc. Ltd. Fluke Technical Center 1330 Marie Victorin Blvd. E. Zip: J4G 1A2 Tel. (514) 670-1212</p>

Sales and Service Locations — International

Supplied and supported by Fluke (Nederland) B.V., P.O. Box 5053, Zevenheuvelenweg 53, Tilburg, Netherlands.			
<p>EUROPE</p> <p>AUSTRIA *Walter Rekirsh Elektronische Gerate GmbH & Co. Vertrieb KG Liechtensteinstrasse 97/6 A-1090 Vienna, Austria Tel. (222) 347646-0</p> <p>BELGIUM *C. N. Rood S/A 37 Place de Jamblinne de Meux B-1040 Brussels, Belgium Tel. (02) 27352135</p> <p>CYPRUS Chris Radiovision Ltd. P.O. Box 1989 Nicosia, Cyprus Tel. 66121</p> <p>DENMARK *Tage Olsen A/S Ballerup Byveg 222 DK-2750 Ballerup Tel. (01) 2-65 81 11</p> <p>FINLAND *Oy Findip AB Teollisuustie 7 02700 Kauniainen Helsinki, Finland Tel. (080) 502255</p> <p>FRANCE *M. B. Electronique S.A. Rue Fourney ZAC de BUC B. P. No. 31 78530 BUC, France Tel. (01) 9563130</p> <p>GERMAN FEDERAL REPUBLIC *Fluke (Deutschland) GmbH 4-Dusseidorf Meineckestrasse 53 West Germany Tel. 211-450831</p>	<p>*Fluke (Deutschland) GmbH 8000 Munich 80 Vertriebsuro Bayern Rosenheimer Strasse 139 West Germany Tel. 089-404061</p> <p>GREECE *Hellenic Scientific Representations Ltd. 11 Vrassida Street Athens 612, Greece Tel. (021) 7792320</p> <p>ITALY *Sistrel S.p.A. Via Giuseppe Armellini No. 39 00143 Rome, Italy Tel. (06) 5915551</p> <p>*Sistrel S.p.A. Via Timavo 66 20099 Sesto S. Giovanni (Milan) Italy Tel. (02) 2476693</p> <p>NETHERLANDS *C.N. Rood, B.V. Cort van der Lindenstraat 11-13 Rijswijk ZH2280AA Netherlands Tel. (070) 996360</p> <p>NORWAY *Morgenstjerne & Co. A/A Konghellegate 3 P.O. Box 6688, Rodelokka Oslo 5, Norway Tel. (02) 356110</p> <p>PORTUGAL *Equipamentos De Laboratorio Ltda. P.O. Box 1100 Lisbon 1, Portugal Tel. (019) 976551</p>	<p>SPAIN *Hispano Electronica S.A. Poligono Industrial Urtinsa Apartado de Correos 48 Alcorcon (Madrid), Spain Tel. 09-341-6194108</p> <p>SWEDEN *Teleinstrument AB P.O. Box 490 S-162 Vallingby-4 Sweden Tel. (08) 380370</p> <p>SWITZERLAND *Traco Electronic AG Jenatschstrasse 1 8002 Zurich, Switzerland Tel. (01) 2010711</p> <p>TURKEY *Erkman Elektronik Aletler Necatibey Cad 92/2 Karakoy/Istanbul Turkey Tel. 441546</p> <p>UNITED KINGDOM *Fluke International Corp. Colonial Way Watford Herts WD2 4TT, England Tel. (0923) 40511</p> <p>MIDDLE EAST</p> <p>EGYPT Lotus Engineering Organisation P.O. Box 1252 Cairo, Egypt Tel. 71617</p> <p>IRAN *Irantronics Company Ltd. 20 Salm Road, Roosevelt Ave. Tehran, Iran Tel. 828294</p>	<p>ISRAEL *R.D.T. Electronics Engineering Ltd. 46, Sokolov Street Ramat Hasharon 47235, Israel Tel. 482311</p> <p>JORDAN Trading & Agricultural Development Co. P.O. Box 567 Amman, Jordan Tel. 23052</p> <p>KUWAIT Tareq Company P.O. Box Safat 20506 Kuwait, Arabian Gulf Tel. 436100</p> <p>LEBANON Mabek P.O. Box 11-3823 Beirut, Lebanon Tel. 252631</p> <p>MOROCCO Mainvest Residence Moulay Ismail Bat.C Boulevard Moulay Slimane, Rabat, Morocco Tel. 276-64</p> <p>SAUDI ARABIA Electronic Equipment Marketing Est. P.O. Box 3750 Riyadh, Saudi Arabia Tel. 32700</p> <p>SYRIA Mabek Electronics C/O Messers G. Ghazzi P.O. Box 4238 Damascus, Syria</p>
<p>*Technical Service Available</p> <p style="text-align: right;">Customers in the following countries: Bulgaria, Czechoslovakia, Hungary, Poland, Romania, U.S.S.R. and Yugoslavia. Contact: Amtest Associates Ltd., P.O. Box 55, Addlestone, Surrey, KT 15 1DU, England, Tel. (0932) 52121</p>			

Sales and Service Locations — International (Concluded)

Supplied and supported by Fluke International Corporation, P.O. Box 43210, Mountlake Terrace, WA 98043

ARGENTINA

*Coasin S.A.
Virrey del Pino 4071
Buenos Aires, Argentina
Tel. 523185

AUSTRALIA

*Elmeasco Instruments Pty. Ltd.
P.O. Box 30
Concord, N.S.W.
Australia 2137
Tel. (02) 736-2888

Elmeasco Instruments Pty. Ltd.
P.O. Box 107
Mt. Waverly, VIC 3149
Australia
Tel. 233-4044

BANGLADESH

Kabir Brothers Ltd.
97 - Gulshan Ave., Gulshan
G.P.O. Box 693
Dacca-12, Bangladesh
Tel. 303104

BOLIVIA

Coasin Bolivia S.R.L.
Casilla 7295
La Paz, Bolivia
Tel. 40962

BRAZIL

*Arotec S.A.
Industrial e Comercio
Av. Pacaembu 811
Sao Paulo S.P., Brazil
Tel. (67) 2393

*Arotec S.A.
Av. Rio Branco, 277
Grupo 1309
Rio de Janeiro - R. J., Brazil

CHILE

*Intronica Chile Ltda.
Casilla 16228
Manuel Montt 024-Of. D
Santiago 9, Chile
Tel. 44940

COLOMBIA

Coasin Ltda.
Carrera 13, No. 37-37, Of. 407
Ap. Aereo 29583
Bogota DE, Colombia
Tel. 285-0230

ECUADOR

*Proteco Coasin CIA, Ltda.
Edifica "Jerico"
Ave. 12 de Octubre
No. 2285 y Ave. Orellana
(Planta Baja)
Quito, Ecuador
Tel. 529-684

HONG KONG

*Gilman & Co., Ltd.
P.O. Box 56
Hong Kong
Tel. 794266

ICELAND

Kristjan O. Skagfjord Ltd.
P.O. Box 906
Reykjavik, Iceland
Tel. 24120

INDIA

*Hinditron Services Pvt. Ltd.
69/A.L. Jagmohandas Marg
Bombay 400 006, India
Tel. 365344

*Hinditron Services Pvt. Ltd.
412 Raj Mahal Vilas Extn.
Bangalore 560 006, India
Tel. 33139

INDONESIA

*P.T. DWI Tunggal Jaya Sakti
Sangga Buana Bldg., 1st Floor
J1 Senen Raya 44, P.O. Box 4435
Jakarta, Indonesia
Tel. 367390

P.T. DWI Tunggal Jaya Sakti
Jalan Sasakgantung 45
Bandung, Indonesia

JAPAN

Panetron Division
Tokyo Electron Ltd.
1 Higashikata-machi
Midori-ku
Yokohama 226, Japan
Tel. (045) 471-8811

*John Fluke Mfg. Co., Inc.
1 Higashikata-machi
Midori-ku
Yokohama 226, Japan
Tel. (045) 473-5425
Tlx: 3823-666 FLUKJP J

KENYA

Adcom Limited Inc.
P.O. Box 30070
Nairobi, Kenya
East Africa
Tel. 331955

KOREA

*Electro-Science Korea Co.
C.P.O. Box 8446
Rm. 1201 Bowon Bldg.
490 Chongro-5Ka
Chongro-ku
Seoul, Korea
Tel. 261-7702

MALAYSIA

O'Connor's (Pte) Ltd.
P.O. Box 1197
Kota Kinabalu, Sabah
East Malaysia
Tel. 54082

O'Connor's (Pte) Ltd.
P.O. Box 91
Petaling Jaya, Selangor
West Malaysia
Tel. 51563

MEXICO

*C.J. Christensen S.A. de C.V.
Instrumentos Electronicos
de Medicion
Melchor Ocampo 150-8
Mexico 4, D.F., Mexico
Tel. (905) 535-2258

NEW ZEALAND

*W & K McLean Ltd.
P.O. Box 3097
Auckland, New Zealand
Tel. 587-037

NIGERIA

Mofat Engineering Co., Ltd.
P.O. Box 6369
Lagos, Nigeria

PAKISTAN

Pak International Operations
505 Muhammadi House
McLeod Road
P.O. Box 5323
Karachi, Pakistan
Tel. 221127

PERU

*Importaciones
y Representaciones
Electronicas S.A.
Avda, Franklin D. Roosevelt 105
Lima 1, Peru
Tel. 288650

SINGAPORE

*O'Connor's (Pte) Ltd.
98 Pasir Panjang Road
Singapore 5, Singapore
Tel. 637944

SOUTH AFRICA

*Fluke S.A. (Pty) Ltd.
P.O. Box 39797
Bramley 2018
Republic of South Africa
Tel. (011) 786-3170

TAIWAN

CCT Associates, Inc.
P.O. Box 24209
Taipei, Taiwan
Republic of China
Tel. (02) 391-6894

THAILAND

Dynamic Supply
Engineering R.O.P.
No. 56 Ekamai, Sukhumvit 63
Bankok 11, Thailand
Tel. 914434

URUGUAY

Coasin Uruguay S.R.L.
Cerrito 617-4° Piso
Montevideo, Uruguay
Tel. 917978

VENEZUELA

*Coasin C.A.
APDO Postal 50939
Sabana Grande No. 1
Caracas 105, Venezuela
Tel. 782-9109

*Technical Service Available

Sales Offices — U.S. and Canada

John Fluke Mfg. Co., Inc.
 P.O. Box 43210, Mountlake Terrace, WA 98043
 Tel. (206) 774-2211 Toll Free: (800) 426-0361 TWX: 910-449-2850 TLX: 32-0013 Cable: Fluke

United States

AK, Anchorage

Harry Lang & Associates
 1406 W. 47th Ave.
 Anchorage, AK 99503
 (907) 279-5741

AL, Huntsville

John Fluke Mfg. Co., Inc.
 3322 S. Memorial Parkway
 Huntsville, AL 35807
 (205) 881-6220

AZ, Phoenix

John Fluke Mfg. Co., Inc.
 7319 E. Stetson Drive
 Scottsdale, AZ 85251
 (602) 994-3883

CA, Burbank

John Fluke Mfg. Co., Inc.
 2020 N. Lincoln Blvd.
 Burbank, CA 91504
 (213) 849-7181

CA, Santa Clara

John Fluke Mfg. Co., Inc.
 2300 Walsh Ave.
 Santa Clara, CA 95050
 (408) 244-1505

CA, Tustin

John Fluke Mfg. Co., Inc.
 15441 Red Hill Ave, Unit B
 Tustin, CA 92680
 (714) 752-6200

CO, Denver

Barnhill Three, Inc.
 1980 S. Quebec St., Unit 4
 Denver, CO 80231
 (303) 750-1222

CT, Hartford

John Fluke Mfg. Co., Inc.
 124 Hebron Ave.
 Glastonbury, CT 06033
 (203) 633-0777

FL, Orlando

John Fluke Mfg. Co., Inc.
 940 N. Fern Creek Ave.
 Orlando, FL 32803
 (305) 896-4881

HI, Honolulu

EMC Corporation
 2979 Ualena St.
 Honolulu, HI 96819
 (808) 847-1138

IL, Chicago

John Fluke Mfg. Co., Inc.
 1400 Hicks Road
 Rolling Meadows, IL 60008
 (312) 398-0850

IN, Indianapolis

John Fluke Mfg. Co., Inc.
 5610 Crawfordsville Rd.
 Suite 802
 Indianapolis, IN 46224
 (317) 244-2456

MA, Waltham

John Fluke Mfg. Co., Inc.
 244 Second Avenue
 Waltham, MA 02154
 (617) 890-1600

MD, Baltimore

John Fluke Mfg. Co., Inc.
 11501 Huff Court
 Kensington, MD 20795
 (301) 881-3370
 (301) 792-7060 (Baltimore)

MI, Detroit

John Fluke Mfg. Co., Inc.
 13955 Farmington Rd.
 Livonia, MI 48154
 (313) 522-9140

MN, Minneapolis

John Fluke Mfg. Co., Inc.
 10800 Lyndate Ave. S.
 Minneapolis, MN 55420
 (612) 884-4336

MO, Kansas City

John Fluke Mfg. Co., Inc.
 4406 Chouteau Traffic Way
 Kansas City, MO 64117
 (816) 454-5836

MO, St. Louis

John Fluke Mfg. Co., Inc.
 300 Brooks Dr., Suite 100
 Hazelwood, MO 63042
 (314) 731-3388

NC, Greensboro

John Fluke Mfg. Co., Inc.
 1310 Beaman Place
 Greensboro, NC 27408
 (919) 273-1918

NJ, Clifton

John Fluke Mfg. Co., Inc.
 460 Colfax Avenue
 Clifton, NJ 07013
 (201) 778-4040
 (516) 935-6672 (Long Island)

NM, Albuquerque

Barnhill Three, Inc.
 1410 D Wyoming N.E.
 Albuquerque, NM 87112
 (505) 299-7658

NY, Rochester

John Fluke Mfg. Co., Inc.
 4515 Culver Road
 Rochester, NY 14622
 (716) 266-1400

OH, Cleveland

John Fluke Mfg. Co., Inc.
 7830 Freeway Circle
 Middleburg Heights, OH 44130
 (216) 234-4540

OH, Dayton

John Fluke Mfg. Co., Inc.
 4756 Fishburg Rd.
 Dayton, OH 45424
 (513) 233-2238

PA, Philadelphia

John Fluke Mfg. Co., Inc.
 1010 West 8th Ave., Suite H
 King of Prussia, PA 19406
 (215) 265-4040

TX, Austin

John Fluke Mfg. Co., Inc.
 111 W. Anderson Lane
 Suite 213
 Austin, TX 78752
 (512) 458-6279

TX, Dallas

John Fluke Mfg. Co., Inc.
 14400 Midway Road
 Dallas, TX 75240
 (214) 233-9990

TX, Houston

John Fluke Mfg. Co., Inc.
 1014 Wirt Road, Suite 270
 Houston, TX 77055
 (713) 683-7913
 (512) 222-2726 (San Antonio)

UT, Salt Lake City

Barnhill Three, Inc.
 54 West 2100 South
 Suite 3
 Salt Lake City, UT 84115
 (801) 484-4496

WA, Seattle

John Fluke Mfg. Co., Inc.
 691 Strander Blvd.
 Seattle, WA 98168
 (206) 575-3765

Canada

ALB, Calgary

Allan Crawford Assoc., Ltd.
 2280 - 39th N.E.
 Calgary, ALB T2E 6P7
 (403) 276-9658

BC, North Vancouver

Allan Crawford Assoc., Ltd.
 3795 William Street
 Burnaby, BC Y5C 3H3
 (604) 294-1326

NS, Halifax

Allan Crawford Assoc., Ltd.
 Suite 201, Townsend Pl.
 800 Windmill Road
 Burnside Industrial Park
 Dartmouth, NS B3B 1L1
 (902) 469-7865

ONT, Ottawa

Allan Crawford Assoc., Ltd.
 1299 Richmond Road
 Ottawa, ONT K2B 7Y4
 (613) 829-9651

ONT, Toronto

Allan Crawford Assoc., Ltd.
 6503 Northam Drive
 Mississauga, ONT L4V 1J5
 (416) 678-1500

QUE, Montreal

Allan Crawford Assoc., Ltd.
 1330 Marie Victorin Blvd. E.
 Longueuil, QUE J4G 1A2
 (514) 670-1212

For Canadian areas not listed, contact the office nearest you or Allan Crawford Assoc. Ltd., Mississauga (Toronto), Ontario.

For more information on Fluke products or Sales Offices you may dial (800) 426-0361 toll free in most of U.S. From Alaska, Hawaii, Washington, or Canada phone (206) 774-2481. From other countries phone (206) 774-2398.

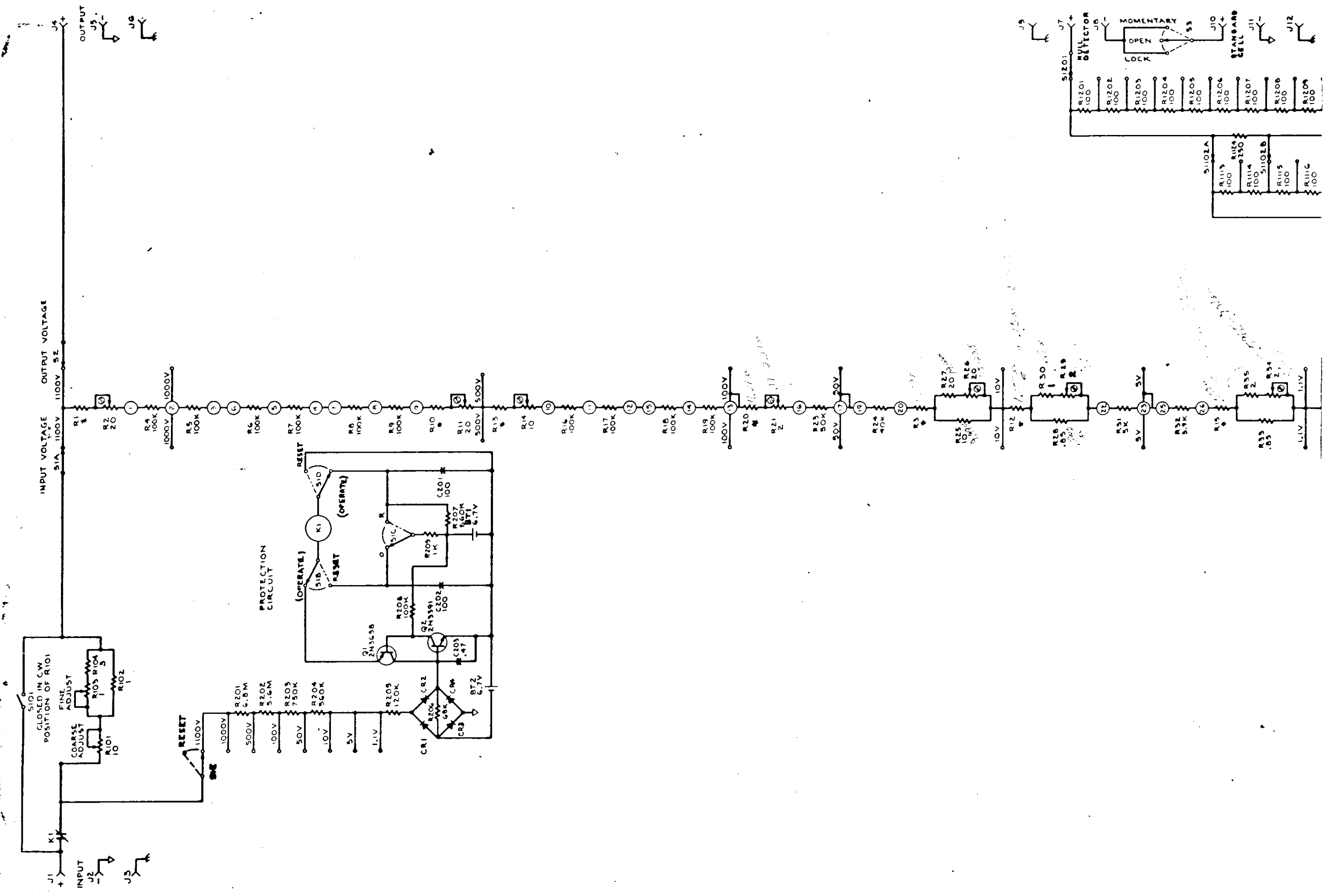

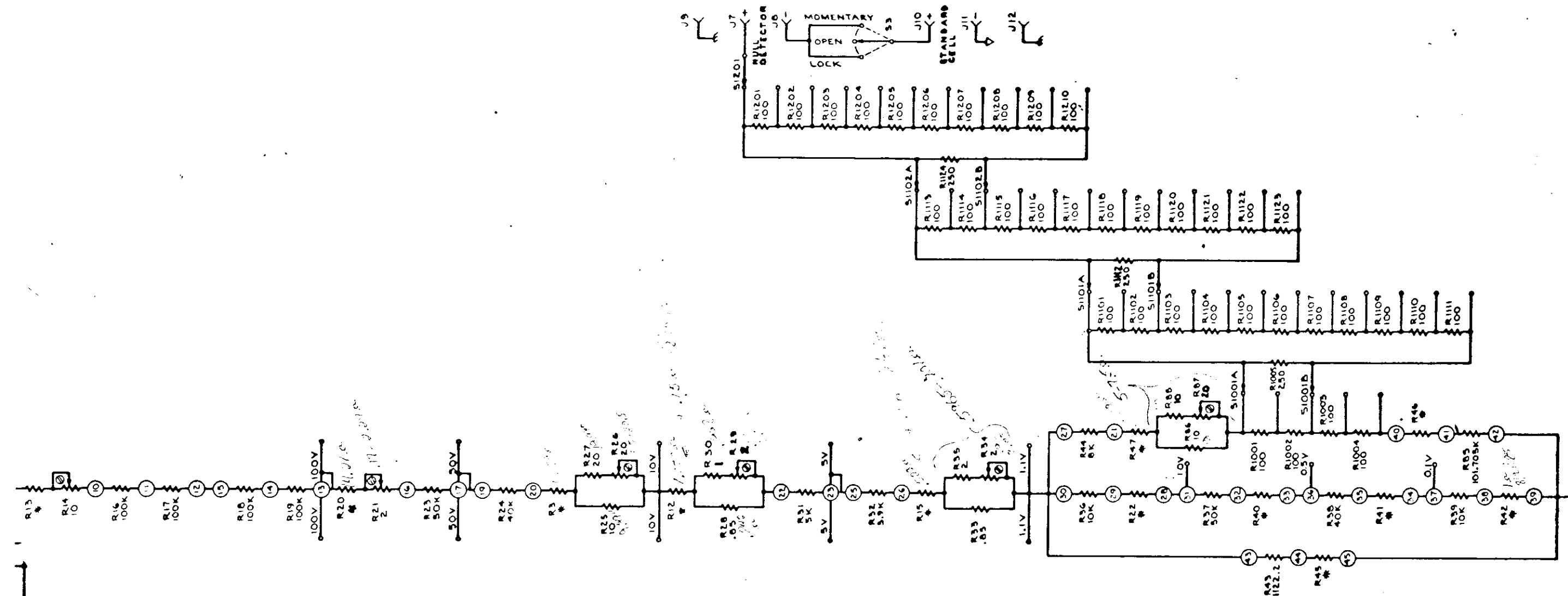

NOTES

- ∇ INDICATES CIRCUIT COMMON.
 - ⚡ INDICATES CHASSIS GROUND.
 - ⊙ INDICATES INTERNAL ADJUSTMENT.
 - INDICATES PART SELECTED AT FACTORY.
- UNLESS OTHERWISE INDICATED RESISTANCES ARE IN OHMS AND CAPACITANCES ARE IN MICROFARADS.

FUNCTIONAL SCHEMATIC REFERENCE DIVIDER MODEL 750A
MODEL 750A SER. NO. 123 & ON
JOHN FLUKE MFG. CO., INC. <small>P. O. Box 7478 Seattle, Washington 98122</small>

